

Webasto BLUE COOL MARINE AIR-CONDITIONING

3 or 4 COMPRESSOR CHILLER
UNITS (60000 to 572000 BTU)



TWIN COMPRESSOR
CHILLER UNITS (24 to
96000 BTU)



AIR-HANDLERS



SELF-CONTAINED UNITS
5000 to 20000 BTU



SELF-CONTAINED UNITS
24000 to 30000 BTU



SPLITAIR UNITS 5000 to
20000 BTU

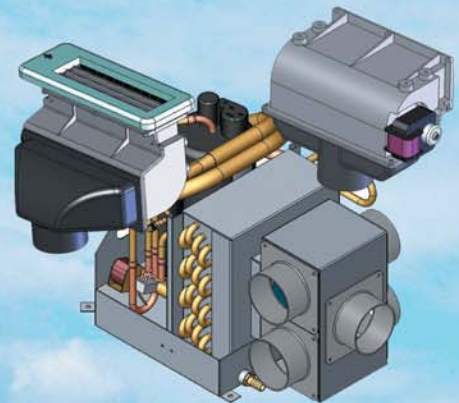

2006 Catalogue

Webasto AG - Special Products & Markets

**Kraillinger Strasse 5,
Tel. : +49(0) 89 8 57 94 543**

**82131 STOCKDORF,
Fax : +49(0) 89 8 57 94 753**

**Germany
Website : www.webasto.de**

CONTENTS

SECTION 1 - MARINE AIR-CONDITIONING

1) BLUE COOL CLASSIC - Self Contained Units - General Outlines	3
Blue Cool Classic units - 5000 to 30000 BTU	5
2) BLUE COOL SELECT - Split-Air Units - General Outlines.....	6
SplitAir units from 5000 to 20000 BTU	7
Electronic Controls for Self-Contained and Split-Air Units.....	11
3) BLUE COOL PREMIUM - Chilled Water Systems - General Outlines	12
Condensing Units - 1,2 and 3 Compressor Modules - 12000 to 252000 BTU	14
Condensing Units - 4 Compressor Modules - 240000 to 572000 BTU	15
Fresh-air and Extraction Air Units	15
4) AIR-HANDLERS FOR CHILLED WATER SYSTEMS	16
5) QUICK BTU CALCULATION GUIDE & AIR-DUCTING	17
6) ELECTRONIC CONTROLS - Chilled Water Systems	18
7) PUMPS + Accessories - Air-Conditioning	20
8) AIR GRILLES + Accessories	22
9) AIR DUCTING + Accessories	23
10) CHILLED WATER Piping + Accessories	25
11) CUPRO-NICKEL Sea-water condensers	26

Webasto - AIR-CONDITIONING

BLUE COOL CLASSIC Units (Self Contained)

F
U
N
C
T
I
O
N
I
N
G
P
R
I
N
C
I
P
L
E
S

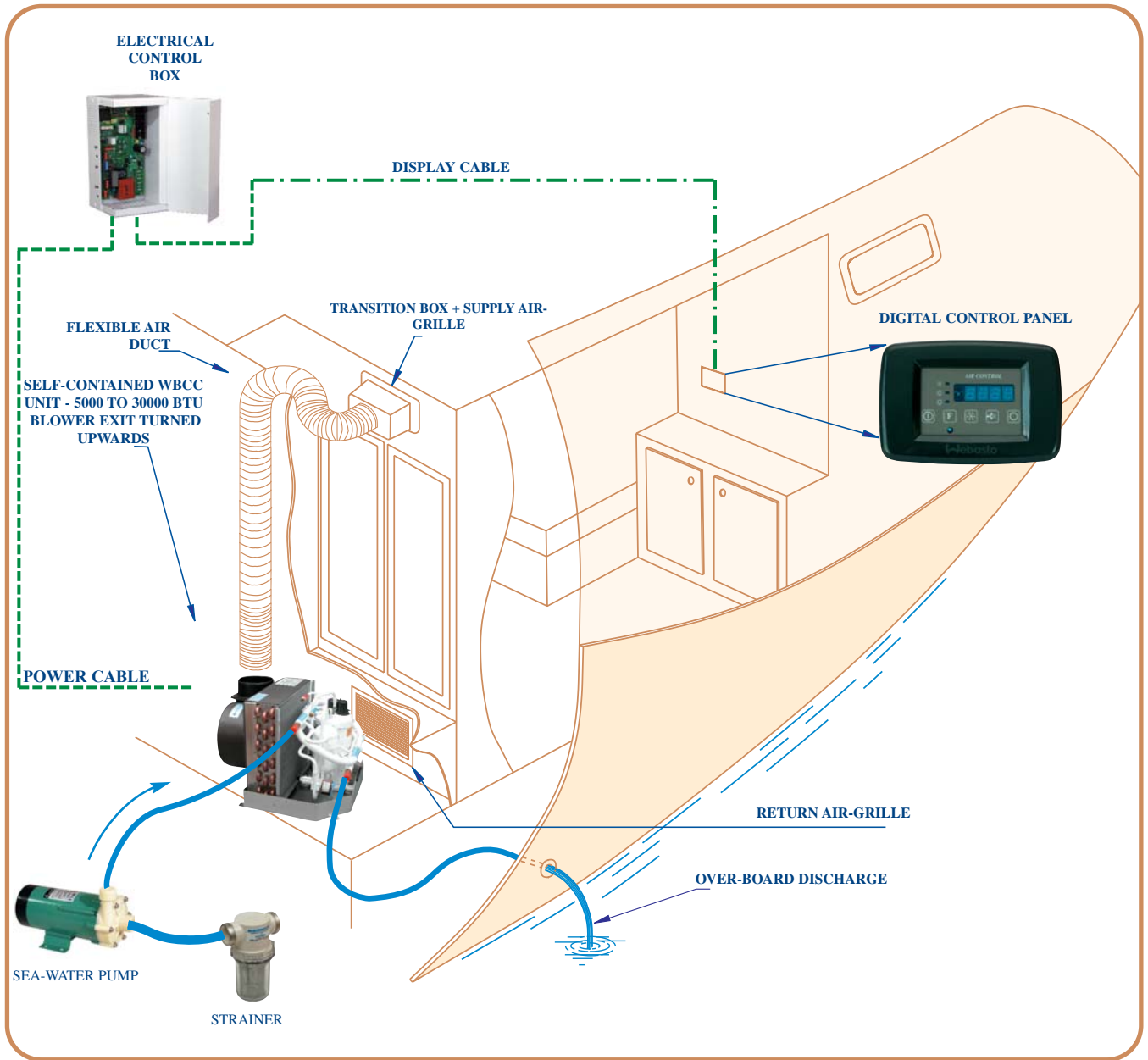

DIGITAL CONTROL PANEL

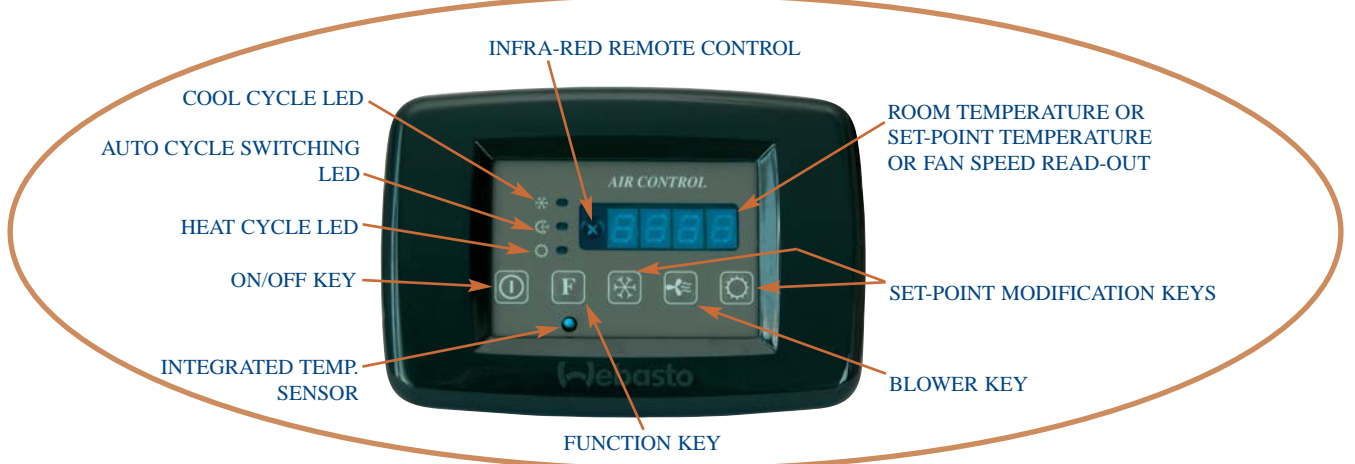

Webasto AG - Special Products & Markets - Kraillinger Strasse 5 - 82131 Stockdorf - Germany
 Tel. : +49(0) 89 8 57 94 543 Fax : +49(0) 89 8 57 94 753 Website : www.webasto.de

HOW DOES IT WORK ?

All air-conditioning units based on hermetic compressors function on the same principle : a compressor compresses the refrigerant gas which is then condensed to liquid when passing through a sea-water cooled condenser. Next the liquid refrigerant

is injected through a small nozzle and evaporates. This evaporation process produces the refrigeration effect. The evaporation takes place in a tubular finned coil (also called : evaporator coil). A blower draws the air through the evaporator

coil. While passing through the evaporator the temperature of the air is lowered by approximately 15 °C. So far for the general principles.

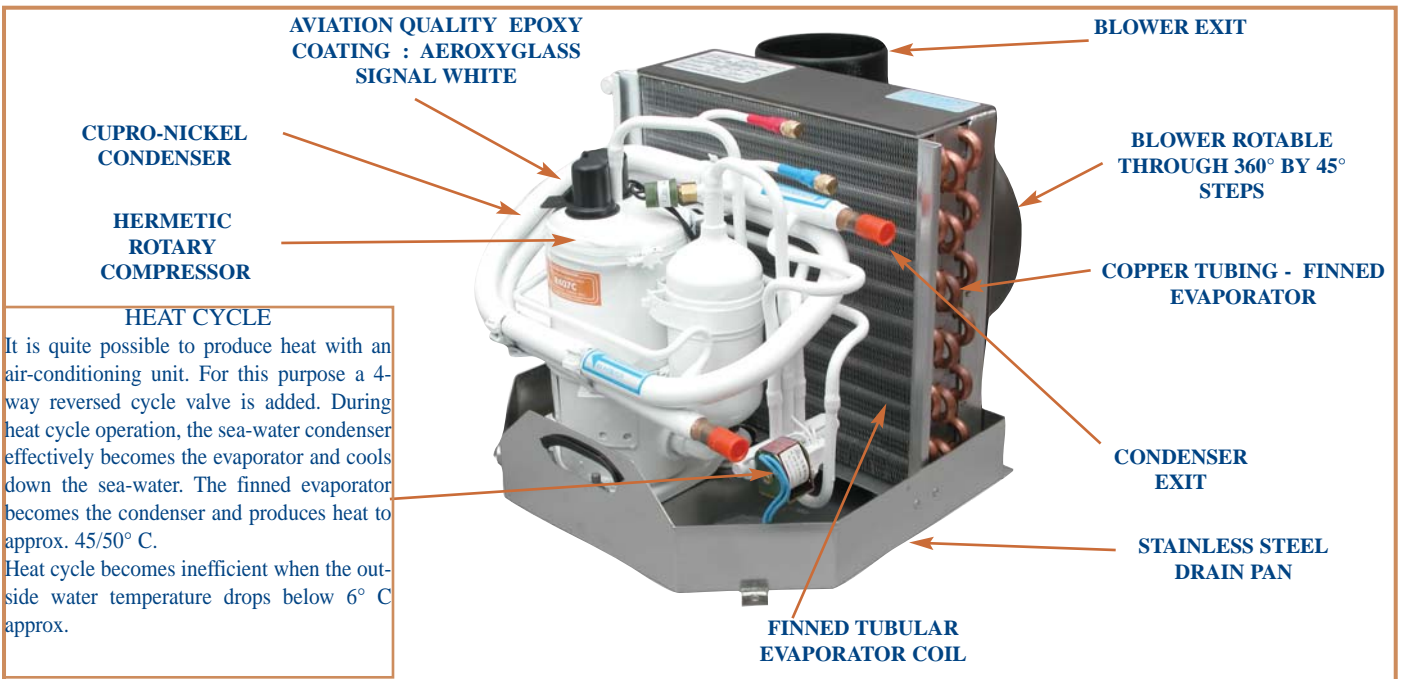

HEAT CYCLE
It is quite possible to produce heat with an air-conditioning unit. For this purpose a 4-way reversed cycle valve is added. During heat cycle operation, the sea-water condenser effectively becomes the evaporator and cools down the sea-water. The finned evaporator becomes the condenser and produces heat to approx. 45/50° C. Heat cycle becomes inefficient when the outside water temperature drops below 6° C approx.

The BLUE COOL CLASSIC Self Contained Units - AN EASY SOLUTION

The self-contained units are extremely compact and include on one single base all the components (i.e. compressor + condenser + evaporator + blower), necessary to cool a cabin, salon/lounge or other volume.

The WBCC units are available in several capacities allowing to match almost all specific volume requirements of the yacht.

Description	Capacity BTU/Watts	230V 50/60 Hz		115V 60 Hz	
		Cool Cycle	Reversible	Cool Cycle	Reversible
WBCC 5/D *)	5000 BTU - 1465 W	WBCL005102	WBCL005101	WBCL006501	WBCL006500
WBCC 6.5/D *)	6500 BTU - 1900 W			WBCL006503	WBCL006502
WBCC 7/D *)	7000 BTU - 2000 W	WBCL005103	WBCL0051010		
WBCC 9/D *)	9000 BTU - 2635 W	WBCL005104	WBCL0051011	WBCL006505	WBCL006504
WBCC 12/D *)	12000 BTU - 3515 W	WBCL005105	WBCL0051012	WBCL006507	WBCL006506
WBCC 16/D *)	16000 BTU - 4690 W	WBCL005106	WBCL0051013	WBCL006509	WBCL006508
WBCC 20/D *)	20000 BTU - 5800 W	WBCL005133	WBCL005132		
WBCC 24/D *)	24000 BTU - 7035 W	WBCL005131	WBCL005130		
WBCC 30/D *)	30000 BTU - 8790 W	WBCL005119	WBCL005118		

*) Rotary Compressors LG Goldstar, Mitsubishi

WBCC MODELS AVAILABLE :

TECHNICAL DESCRIPTION - BLUE COOL CLASSIC Series

MINIMUM STANDARD CONTROL ELEMENTS INCLUDED WITH ALL WBCC SELF-CONTAINED UNITS

Summary : 1 Alu control box (standard for all references WBCC**/D) + 1 display cable + 1 digital control panel (see also Page 11)

ELECTRICAL CONTROL BOX

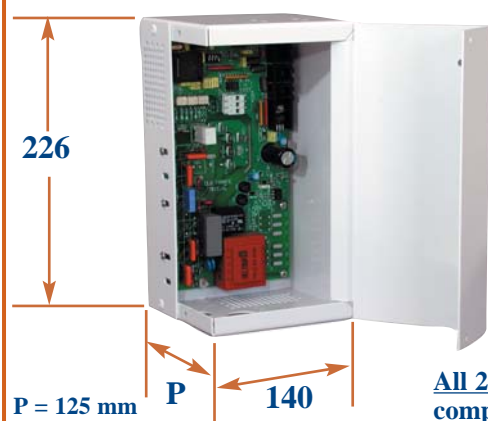

Removable Bezel can be replaced by Vimar or Ticino equivalents

DISPLAY CABLE



SERIES 2004 DIGITAL DISPLAY

All 2004 Digital panels are backwards compatible with the 2000 Series.

WBCC5 To 12/D - 5000 To 12000 BTU



WBCC16 To 20/D - 16000 To 20000 BTU



WBCC24/D - 24000 BTU



WBCC30/D - 30000 BTU



DESCR.	WBCC5	WBCC7 / 6.5	WBCC9	WBCC12	WBCC16	WBCC20	WBCC24	WBCC30
BTU Capacity	5000	7000/6500	9000	12000	16000	20000	24000	30000
Capacity in KW	1.5	2	2.6	3.5	4.7	5.8	7	8.8
Voltage	230V/115V	230V/115V	230V/115V	230V/115V	230V/115V	230V	230V	230V
Frequency	50/60 Hz	50/60 Hz	50/60 Hz	50/60 Hz	50/60 Hz	50/60 Hz	50/60 Hz	50/60 Hz
Aver. Load Amps	2.1/4.2A	2.8/5.4 A	3.2/6.4 A	4.3/8.5 A	5.5/11 A	6.5 A	8 A	9.5 A
Starting Surge	5A/10 A	6A/12 A	7.5A/15 A	9A/18 A	12A/24 A	14 A	18 A	22 A
Refrigerant	R407C/R22	R407C/R22	R407C/R22	R407C/R22	R407C/R22	R407C	R407C	R407C
Net Weight	23 Kgs	24 Kgs	25 Kgs	26 Kgs	33 Kgs	34 Kgs	45 Kgs	50 Kgs
Shipping Weight	30 Kgs	30 Kgs	40 Kgs	40 Kgs	45Kgs	45 Kgs	55 Kgs	60 Kgs
Cooling Pump*)	WB200&250	WB200&250	WB200&250	WB200&350	WB200&350	WB350	WB350	WB1000
Blower	2GRE 120	2GRE 120	2GRE25/140	2GRE35/140	2GRE35/180	2GRE35/180	2 x 35/140	2 x 45/160
Blower Output	275 m3/h	275 m3/h	400 m3/h	500 m3/h	625 m3/h	625 m3/h	2 x 500 m3/h	2 x 550 m3/h
Diam. Cupro	16 mm	16 mm	16 mm	16 mm	16 mm	16 mm	16 mm	16 mm
H -Height	295 mm	295 mm	310 mm	310 mm	330 mm	385 mm	400 mm	400 mm
P - Depth	285 mm	285 mm	380 mm	450 mm	450 mm	450 mm	510 mm	610 mm
D - Diam Air Out	100 mm	100 mm	100 mm	125 mm	125 mm	125 mm	2 x 125 mm	2 x 125 mm
L - Overall L.								
L1 - Lenght L1	300 mm	300 mm	310 mm	310 mm	310 mm	310 mm	315 mm	315 mm
L2 - Length L2	115 mm	115 mm	125 mm	132 mm	132 mm	132 mm	132 mm	132 mm
Suggest. Breaker	8A/16A	10A/20A	12A/24A	16A/32A	20A/40A	20 A	28 A	32 A

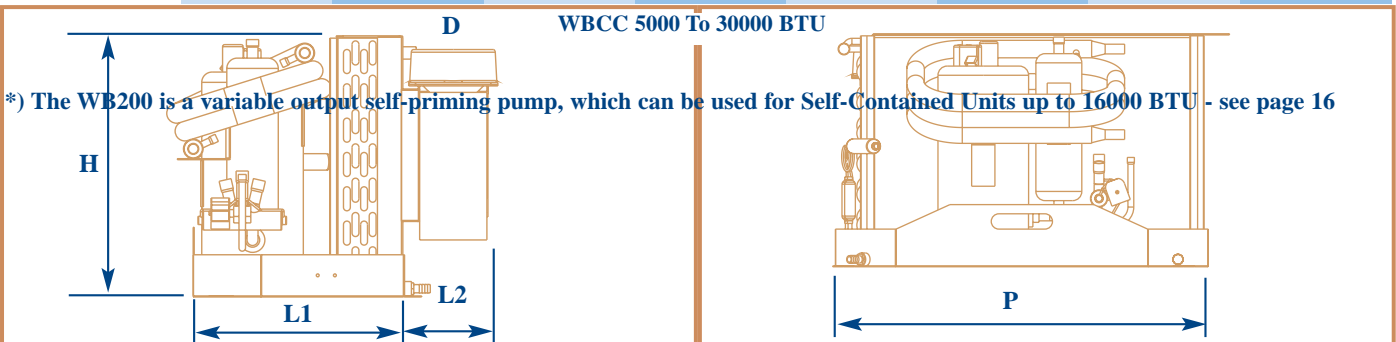

Webasto - AIR-CONDITIONING

SELECT SERIES - SPLIT-AIR UNITS

FUNCTIONING PERFORMANCE INSTALLATION

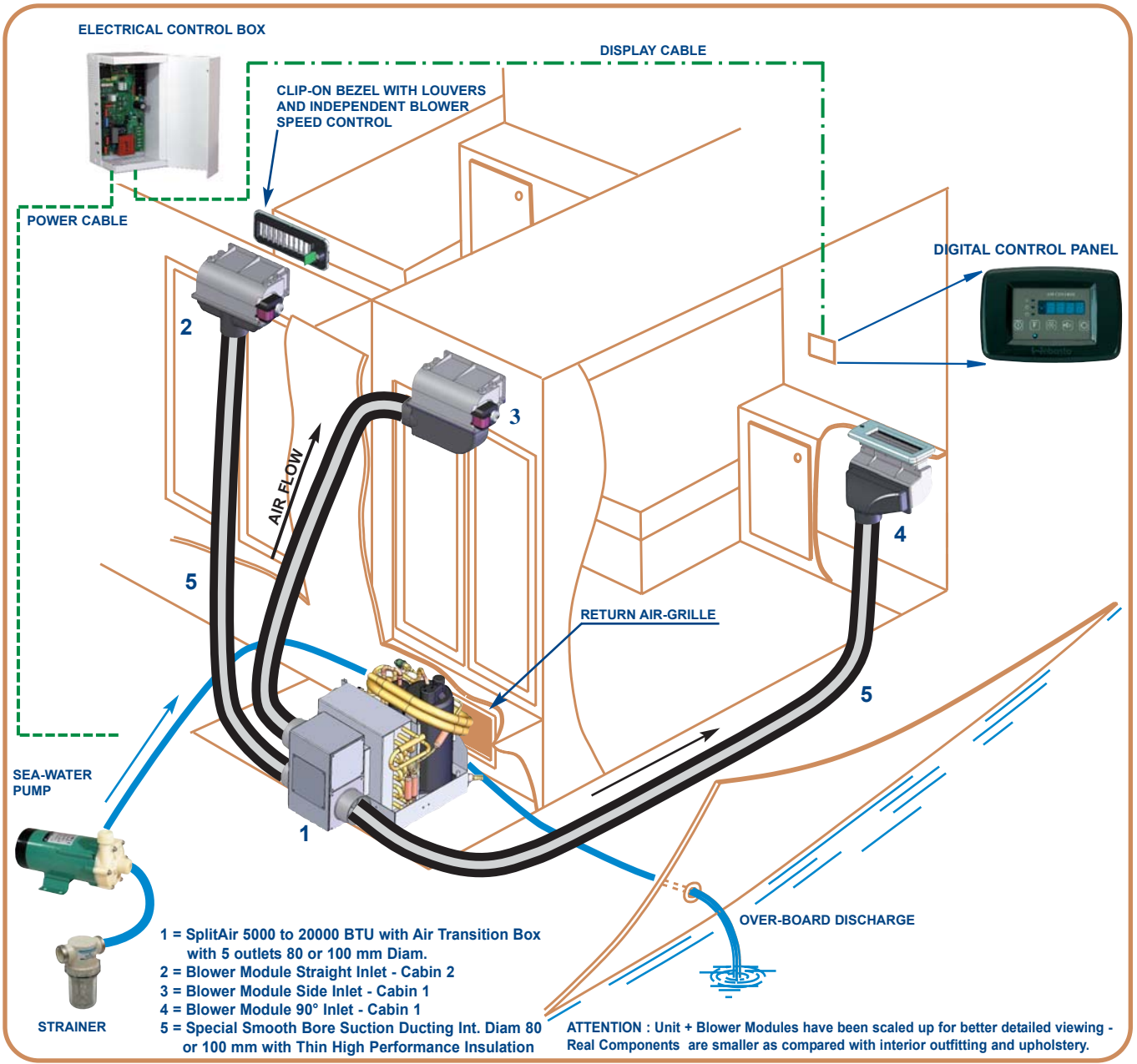

DIGITAL CONTROL PANEL

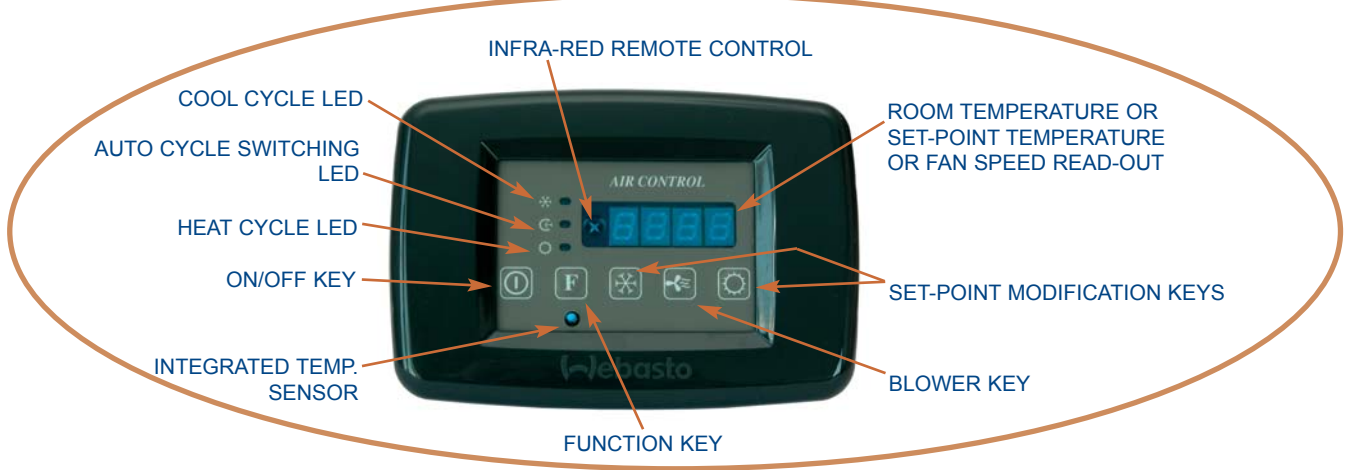

SPLIT-AIR SELECT - HOW DOES IT WORK ?

In a Split-Air system the air is drawn through the common evaporator by remote mounted Split-Air modules connected to the air-transition box by special smoothbore insulated ducting. This principle allows a reduction in duct diameter to 80 and 100 mm and ducts lengths of up to 6/8 meters.

In a typical Split-Air set-up 1, 2 or 3 Split-Air modules are controlled directly by the main digital panel and situated in the main salon or cabin. 1 or more secondary Split-Air modules are placed in other cabins. These secondary SplitAir modules have their own independent blower speed control which allows the occupants of these

cabins to control their own environment.

Special smooth bore ducting with high performance thin insulation material keeps the overall duct diameters down to very reasonable figures :

Int. Diam - Overal Diam With/Insulation
 80 mm 105 mm

SplitAir unit identical to standard self-contained , centrifugal blowers replaced by air-transition box - Standard delivery includes :

- Base unit with air transition box
- Digital display
- 4 m Display Cable
- On/off controller remote blowers modules

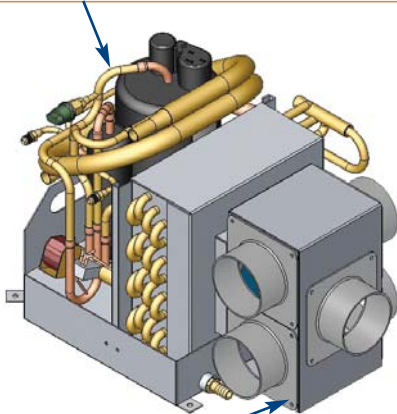

Blower Module 150 m3/Hr - Straight Entry without Air Grille kit

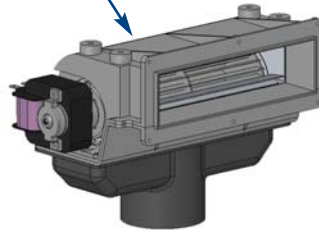

Air Grille kit with or w/o Blower Speed Control - Vert. or Horizontal louvers

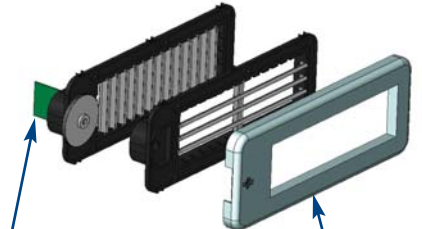

Optional Integrated Blower Speed Control for secondary modules

Clip-on Bezel - Black or White

Blower Module - Side Entry



Blower Module - 90° Angle Entry



Air Transition Box with 5 or 6 exits - 80 or 100 mm - for Splitair ducting to remote Blower Modules - Standard delivery without HOSE RINGS

SPLITAIR SELECT units available :

Description	Capacity BTU/Watts
SELECT 5/D	- 5000 BTU - 1465 Watts
SELECT 7/6.5D	- 7000/6500 Btu - 2000/1900 W
SELECT 9/D	- 9000 BTU - 2635 Watts
SELECT 12/D	- 12000 BTU - 3515 Watts
SELECT 16/D	- 16000 BTU - 4690 Watts
SELECT 20/D	- 20000 BTU - 5800 Watts

Min. Required N° Blower Modules	230V 50/60 Hz		115V 60 Hz	
	Cool Cycle	Reversible	Cool Cycle	Reversible
1	WBCL007215	WBCL007216	WBCL007365	WBCL007366
2	WBCL007217	WBCL007218	WBCL007367	WBCL007368
2	WBCL007219	WBCL007220	WBCL007369	WBCL007370
3	WBCL007221	WBCL007222	WBCL007371	WBCL007372
4	WBCL007223	WBCL007224	WBCL007373	WBCL007374
5	WBCL007225	WBCL007226		

Blower Module 150m3/h Straight Entry without Air Grille
 Blower Module 150m3/h Side Entry without Air Grille
 Blower Module 150m3/h 90° Entry without Air Grille

230V	115V
WBCL007425	WBCL007428
WBCL007427	WBCL007430
WBCL007426	WBCL007429

Air Grille + Bezel + mounting frame w/o Blower Spd Ctrl
 Air Grille + Bezel + mounting frame with Blower Spd Ctrl

Black Vert. Louv.	White Vert. Louv.	Black Hor. Louv.	White Hor. Louv.
WBCL007301	WBCL007303	WBCL007300	WBCL007302
WBCL007311	WBCL007313	WBCL007310	WBCL007312

EXAMPLE DIMENSIONS - SPLIT-AIR MODULE WITH STRAIGHT ENTRY TRANSITION

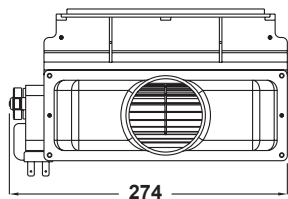

All dimensions in mm

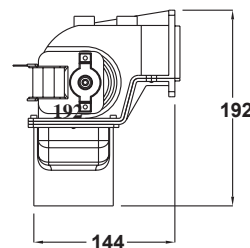
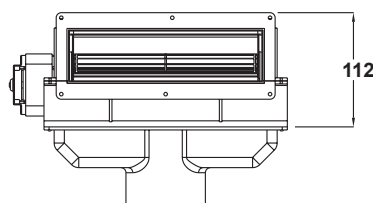

100 mm 128 mm
 125 mm 145 mm

The blower speed control card + thumb-wheel slides easily into the reserved slot in the grille frame - it is always possible to retrofit a blower speed control to existing SplitAir modules.

The Blower Modules have a max unrestricted air-flow of 150 m3/hr which represents approx. 3000 BTU depending on pressure drop, evaporator load , etc

The Blower Modules can be placed horizontally or vertically.

SELECT 5/D & 7/D - 5000 / 7000 BTU

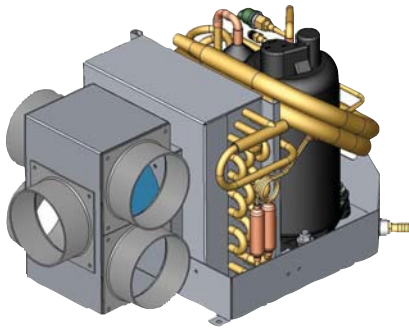

SELECT 9/D - 9000 BTU

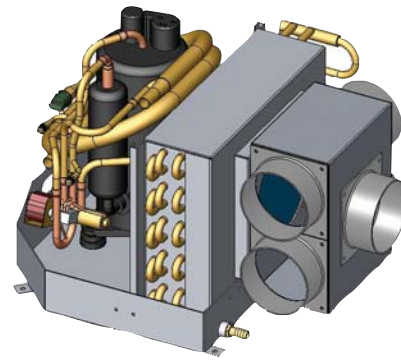

SELECT 12/D - 12000 BTU

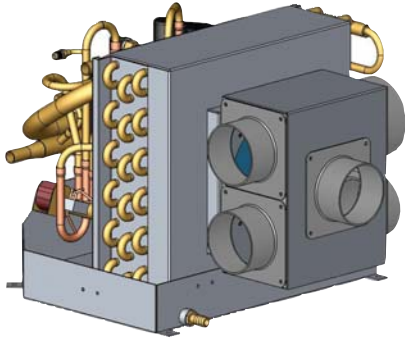

SELECT 16/D & 20/D - 16000 / 20000 BTU

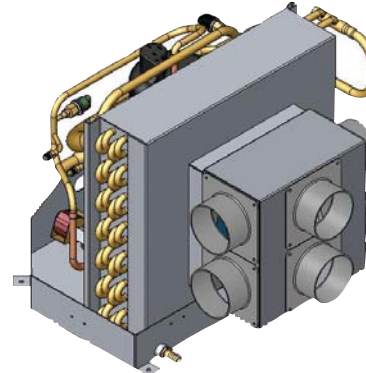

DESCR.	Select 5	Select 7/6.5	Select 9	Select 12	Select 16	Select 20
BTU Capacity	5000	7000/6500	9000	12000	16000	20000
Capacity in KW	1.5	2	2.6	3.5	4.7	5.8
Voltage	230V/115V	230V/115V	230V/115V	230V/115V	230V/115V	230V
Frequency	50/60 Hz	50/60 Hz	50/60 Hz	50/60 Hz	50/60 Hz	50/60 Hz
Aver. Load Amps	2.1A/4.2A	2.8A/5.4 A	3.2A/6.4 A	4.3A/8.5 A	5.5A/11 A	6.5 A
Starting Surge	5A/10A	6A/12 A	7.5A/15 A	9A/18 A	12A/24 A	14 A
Refrigerant	R407C/R22	R407C/R22	R407C/R22	R407C/R22	R407C/R22	R407C
Net Weight	23 Kgs	24 Kgs	25 Kgs	26 Kgs	33 Kgs	34 Kgs
Shipping Weight	30 Kgs	30 Kgs	40 Kgs	40 Kgs	45Kgs	45 Kgs
Cooling Pump	WB250&200	WB250&200	WB250&200	WB350&200	WB350&200	WB350
Diam. Cupro	16 mm	16 mm	16 mm	16 mm	16 mm	16 mm
H -Height	295 mm	295 mm	310 mm	310 mm	335 mm	385 mm
P - Depth	285 mm	285 mm	380 mm	450 mm	450 mm	450 mm
L1 - Lenght L1	300 mm	300 mm	310 mm	310 mm	310 mm	310 mm
L2 - Length L2	115 mm	115 mm	115 mm	120 mm	120 mm	120 mm
Suggest. Breaker	8A	10A/20A	12A/24A	16A/32A	20A/40A	20 A

*) The WB200 is a variable output self-priming pump, which can be used for Self-Contained Units up to 16000 BTU - see page 21

ATTENTION : After selecting your unit, you must order your hose rings (diam 80 mm or 100 mm), your blowers with the desired air entry and your grilles (black or white, vertical or horizontal louvers, with or without electronic speed control). If you run a Split Air unit with less blowers than recommended, the unit may short cycle. It is possible to install more blowers than recommended.

SplitAir 5000 To 20000 BTU

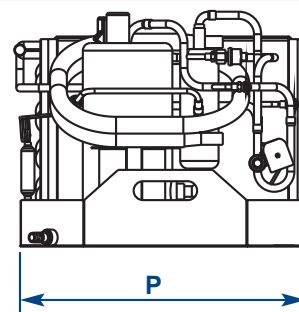
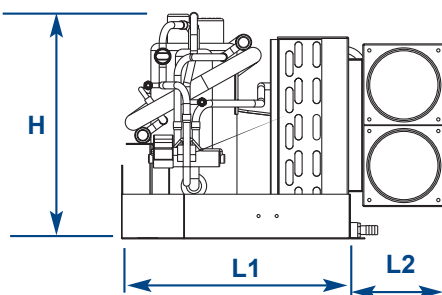

SELECT SYSTEM COMPONENTS AND ACCESSORIES

**AIR TRANSITIONS FOR SPLITAIR
SELECT MODULES & UNITS**

DESCRIPTION	Reference	Length	Diam	Width	Height
1) Air Transition Straight	WBCL007401	239	80	89	79
2) Air Transition Side Entry	WBCL007402	239	80	89	98
3) Air Transition 90° Entry	WBCL007403	239	80	89	97
4) Round Hose Ring diam 80 mm	WBCL007420	110	80	110	40
Round Hose Ring diam. 100 mm	WBCL007421	110	100	110	40
5) SELECT Transition 5/7000 BTU	WBCL007440	133		114	224
SELECT Transition 9000 BTU	WBCL007441	174		114	224
SELECT Transition 12000 BTU	WBCL007442	174		114	224
6) SELECT Transition 16/20000 Btu	WBCL007443	214		114	224
			Int. Diam.	Outside Diam.	
8) Insulated Flex Duct diam. 80mm	WBCL007460	6 m	80	105	
Insulated Flex Duct diam. 100mm	WBCL007461	6 m	100	128	
Insulated Flex Duct diam. 125mm	WBCL007462	6 m	125	145	
10) Blower Speed Ctrl Kit 230/115V	WBCL007480				

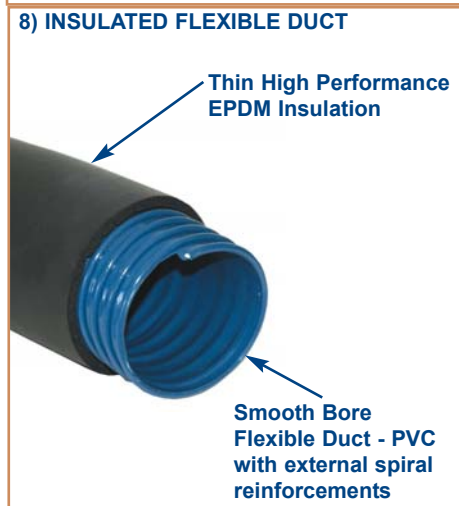
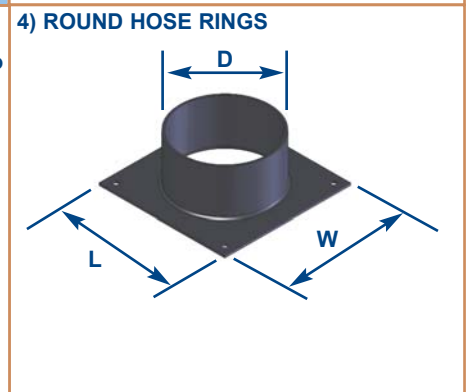
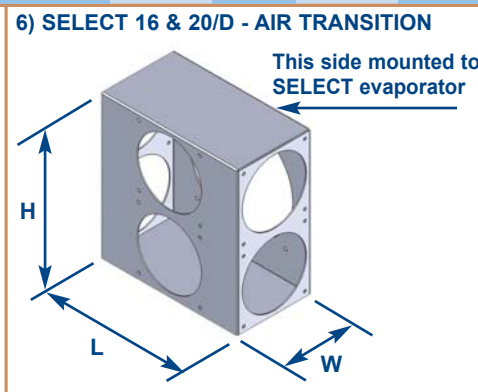
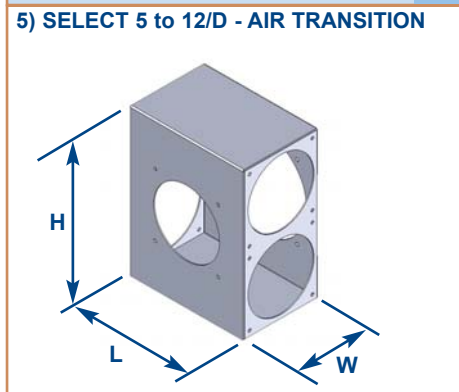
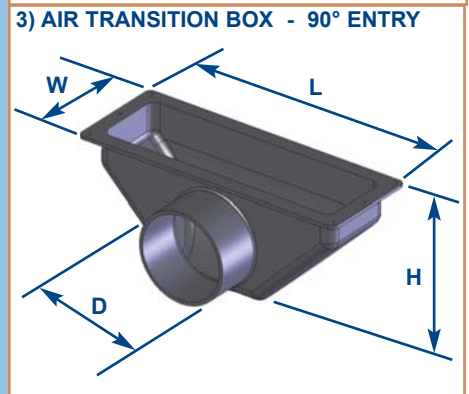
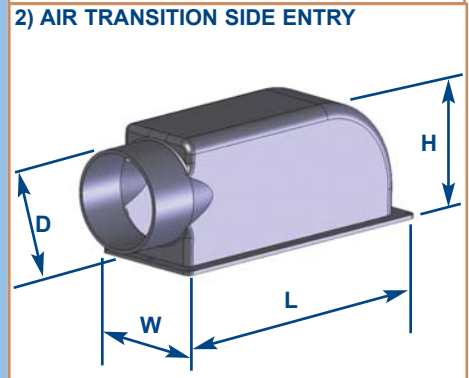

7) SPLITAIR FOR CHILLER SYSTEMS

It is quite possible of course to use the SplitAir modules for the Compact series airhandlers for chiller systems.

This allows to use a single airhandler for 2 or more cabins, add the necessary SplitAir modules and each cabin can then be individually controlled either by simple blower speed control or by blower control + thermostat.

To the right an example of a 12000 BTU Compact airhandler fitted with the SplitAir transition box.

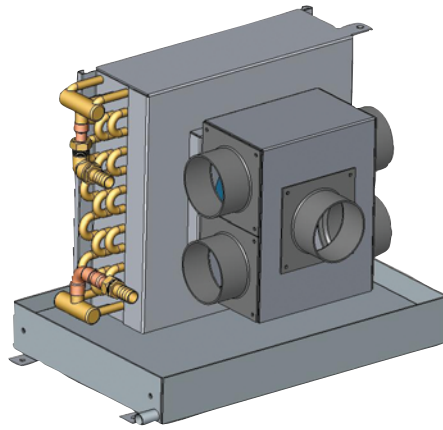

SPLITAIR COMPACT CHILLER AIRHANDLERS :		Ref. W/O 3way valve
Description	Capacity BTU/Watts	
Compact 4500	4500 BTU/1320 Watts	WBCL007501
Compact 6000	6000 BTU/1760 Watts	WBCL007502
Compact 9000	9000 BTU/2635 Watts	WBCL007503
Compact 12000	12000 BTU/3515 Watts	WBCL007504
Compact 16000	16000 BTU/4690 Watts	WBCL007505
Compact 20000	20000 BTU/5800 Watts	WBCL007506
Compact 24000	24000 BTU/7035 Watts	WBCL007507
Compact 30000	30000 BTU/8790 Watts	WBCL007508

In standard delivery the Air Transition box is not fitted with Hose Rings. These should be ordered separately.

NB - All above references are without SplitAir blower modules - these should be acquired according to need : 230V or 115V , with or without Blower Speed control

Webasto - ELECTRONIC CONTROLS

CONTROLS for BLUE COOL CLASSIC & BLUE COOL SELECT

SCHEMATICS :

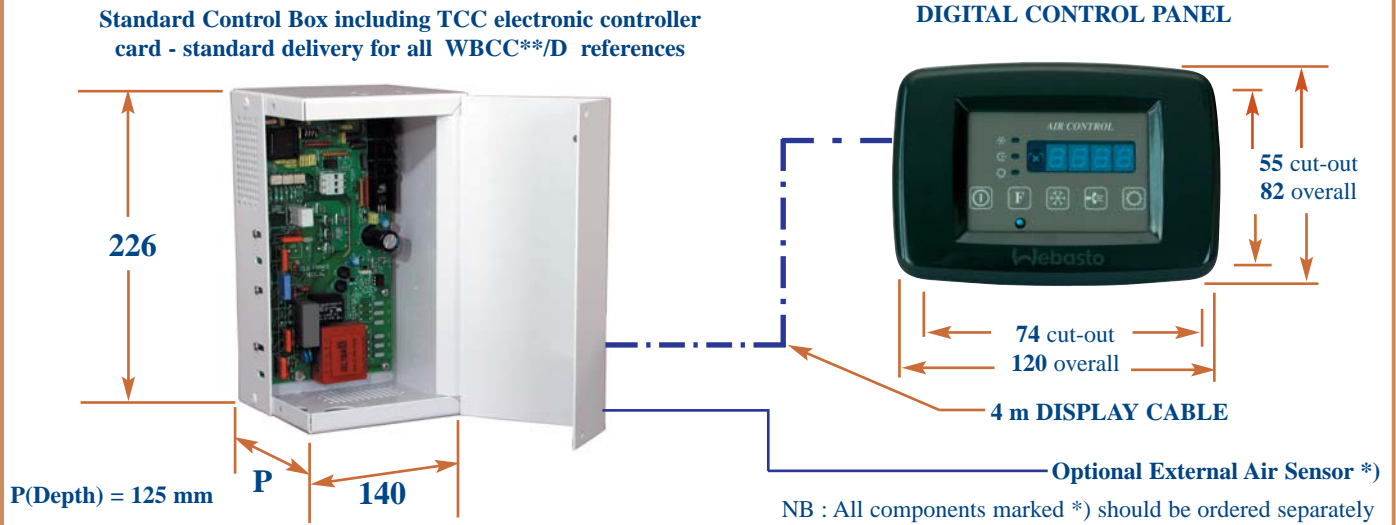

FUNCTIONING PRINCIPLES

The Webasto Digital Air Control Panel is part of a complete electronic control system including the TCC electronic controller card and connecting cables/sensors.

In addition to the immediately available modes and information the following programmable functions can be accessed :

- Automatic / manual cycle switching cool/heat.
- cool cycle/heat cycle only operation
- calibration of all temperature read-outs
- automatic blanking of display.
- fine-tuning of all blower speed settings
- choice between thermostatic and continuous blower control.
- choice between internal and external air sensor.
- possibility to connect 2nd slave WBCC unit including staged compressor start-up
- automatic dehumidification cycle in absence of user.
- direct read-out of evaporator temperature
- choice between manual blower speed control and automatic by temperature differential.
- optional infra-red remote control.
- access code possible for programming access.

EASY CONNECTIONS :

- cable connection to TCC controller by phone type modular jacks.
- installation by adhesive strip or screws.

COLOUR AVAILABLE :

- Grey/Blue

LAST SETTINGS RETAINED :

Non-volatile memory retains last settings.

DIGITAL DISPLAY : OPERATION AND FUNCTION KEYS

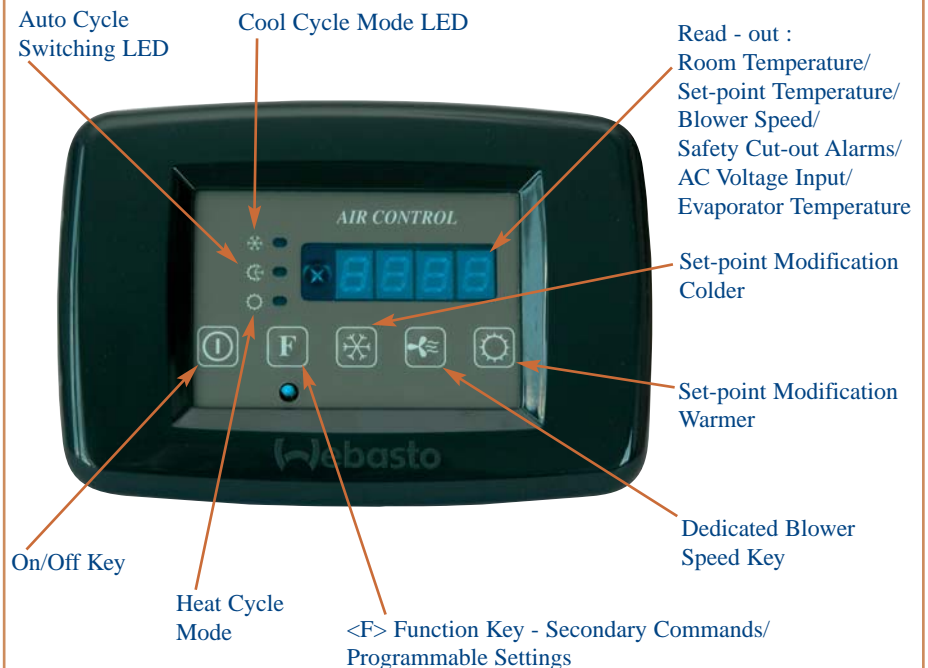

DIGITAL DISPLAYS AND ACCESSORIES

Digital Display <AIR CONTROL> - 2004 Series w/Webasto Bezel ...	Webasto Refer WBCL000824
Display cable between TCC controller and Digital Panel - 4 ml	WBCL000815
Display cable between TCC controller and Digital Panel - 6 ml	WBCL000808
Display cable between TCC controller and Digital Panel - 12 ml	WBCL000809
External Air-sensor with 3 ml cable	WBCL000813
External Air-sensor with 6 ml cable	WBCL000810
External Air-sensor with 12 ml cable	WBCL000812
Fuse-kit for TCC controller card	WBCL000816
WBCC Alu electrical box without TCC controller card	WBCL000821
Evaporator Temperature Sensor 2.5 m	WBCL000368
Infra-red Remote Control - 2000/2004 Series	WBCL000363
Relay Box 2 WBCC's - 1 pump	WBCL001127
Relay Box 3 WBCC's - 1 pump	WBCL001128
TCC V2 controller card 230V AC - 2000/2004 Series	WBCL000823
TCC V2 controller card 115V AC - 2000/2004 Series	WBCL000840
TCC V3 controller card 230V AC - 2005 Series	WBCL000828
TCC V3 controller card 115V AC - 2005 Series	WBCL000829
On/Off controller - SplitAir remote Blower Modules	WBCL000819

Webasto - AIR-CONDITIONING

BLUE COOL PREMIUM - Chilled Water Systems

F
U
N
C
T
I
O
N
I
N
G
P
R
I
N
C
I
P
L
E
S

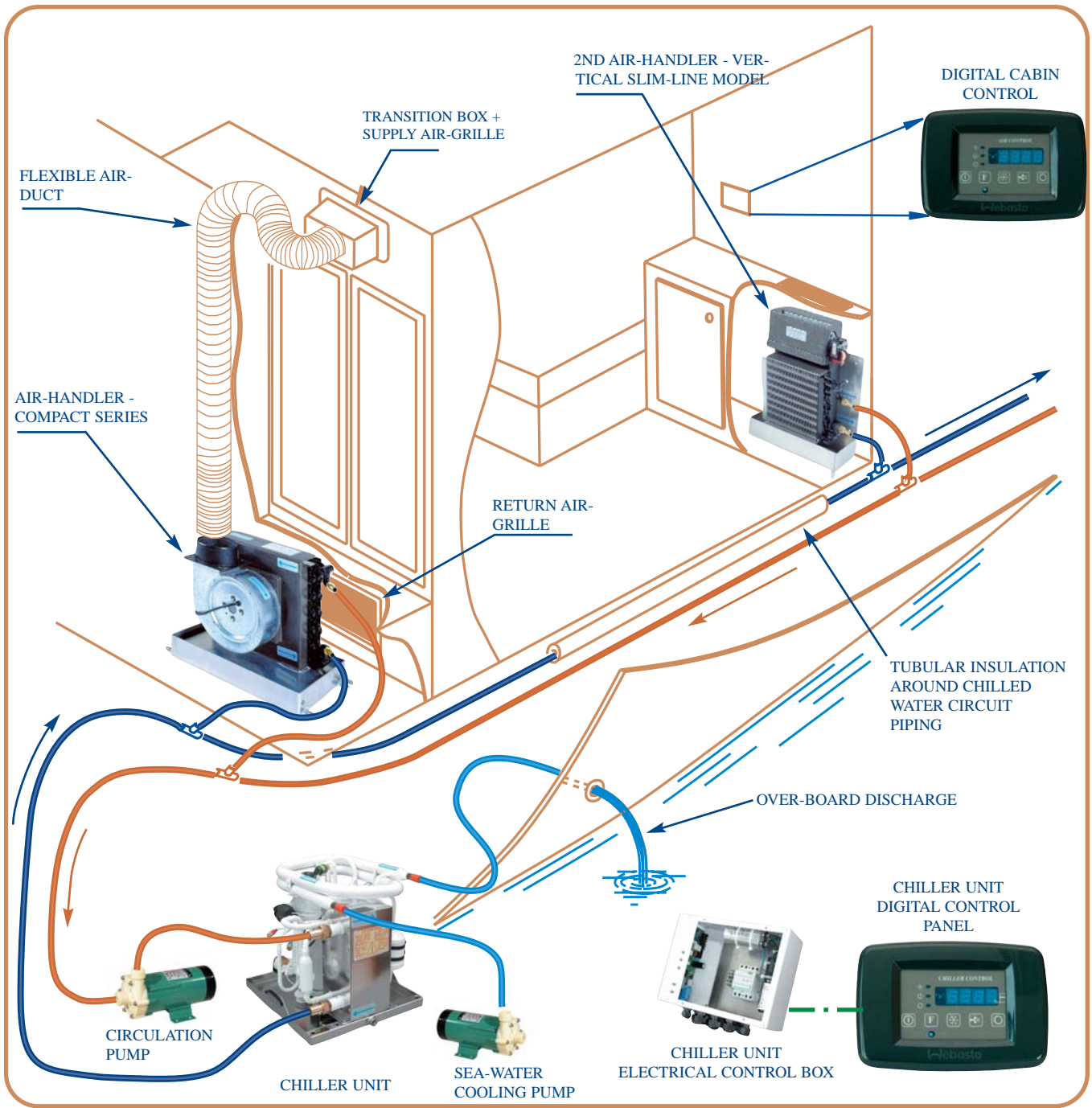

DIGITAL CONTROL PANEL



Webasto AG - Special Products & Markets - Kraillinger Strasse 5 - 82131 Stockdorf - Germany
 Tel. : +49(0) 89 8 57 94 543 Fax : +49(0) 89 8 57 94 753 Website : www.webasto.de

CHILLED WATER SYSTEMS - A FLEXIBLE SOLUTION

Whenever 3 or more independent volumes in a yacht need to be air-conditioned, it becomes interesting to envisage a central

chiller system.

To distribute refrigeration capacity over several independently operating air-hand-

dlers from one single central cooling unit, the most flexible and simple solution is to install a chilled water circulation system

**MODEL SHOWN : New 2004 Series
Mini-Chillers - 12000 to 24000 BTU**

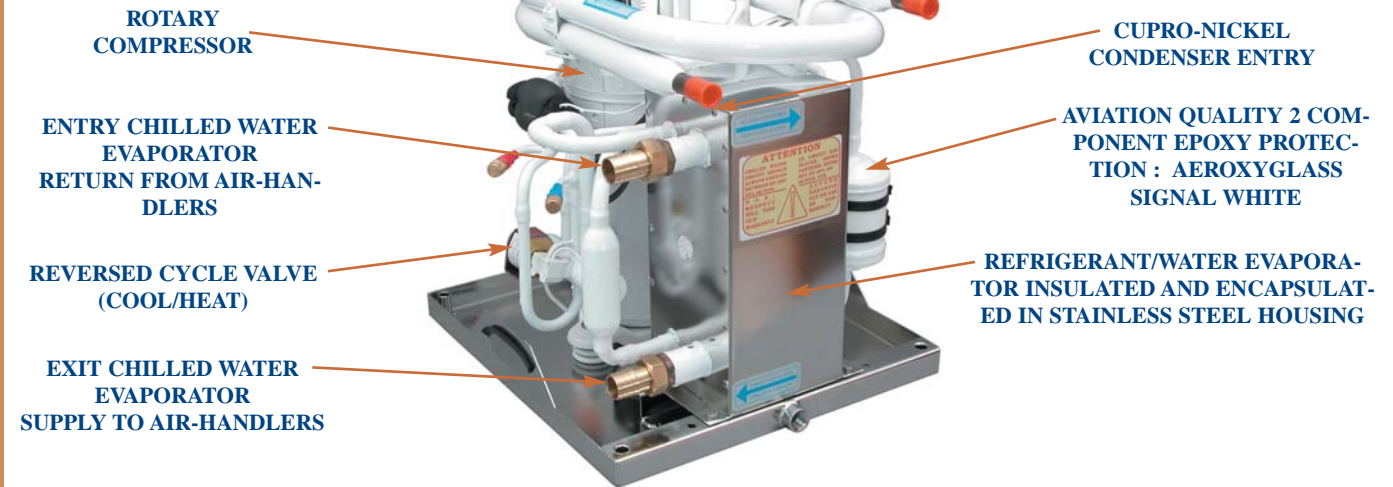

STANDARD CHILLER CONDENSING UNITS AVAILABLE

SINGLE COMPRESSOR MODULES	/D Electr. 230V/400V	Slave 230V/400V	/D Electr. 115V	Slave 115V
WBCLP12 - 12000 BTU - 3.5 Kw *)	WBCL005236	WBCL005237	WBCL006805	WBCL006806
WBCLP16 - 16000 BTU - 4.7 Kw *)	WBCL005203	WBCL005204	WBCL006800	WBCL006801
WBCLP20 - 20000 BTU - 5.8 Kw *)	WBCL005227	WBCL005228	Scroll/D	Scroll/Slve
WBCLP24 - 24000 BTU - 7 Kw *)	WBCL005205	WBCL005206	230V	230V
WBCLP30 - 30000 BTU - 8.8 Kw *)	WBCL005201	WBCL005202	WBCL005207	WBCL005208
WBCLP36 - 36000 BTU - 10.5 Kw	WBCL005209	WBCL005210		
WBCLP42 - 42000 BTU - 12.3 Kw	WBCL005211	WBCL005212		
WBCLP48 - 48000 BTU - 14 Kw	WBCL005213	WBCL005214		
WBCLP60 - 60000 BTU - 17.6 Kw (400V 3Ph)	WBCL005238	WBCL005239		

TWIN COMPRESSOR MODULES - TW/CI - INDEPENDENT Evaporators/Condensers

WBCLP24/TW/LG - 24000 BTU - 7 Kw *)	WBCL005232	WBCL006802
WBCLP32/TW/LG - 32000 BTU - 9.4 KW *)	WBCL005231	WBCL006803
WBCLP40/TW/LG - 40000 BTU - 11.7 Kw *)	WBCL005233	
WBCLP50/TW/LG - 50000 BTU - 14.6 Kw *)	WBCL005234	
WBCLP60/TW/LG - 60000 BTU - 17.6 Kw *)	WBCL005235	
WBCLP60/TW/CI - 60K Btu - 17.6 Kw Scroll	WBCL005216	
WBCLP72/TW/CI - 72000 BTU - 21.1 Kw	WBCL005217	
WBCLP84/TW/CI - 84000 BTU - 24.6 Kw	WBCL005223	
WBCLP96/TW/CI - 96000 BTU - 28.1 Kw	WBCL005224	
Reversible Option **)	WBCL005073	

TRI COMPRESSOR MODULES - TRI/CI - INDEPENDENT Evaporators/Condensers

WBCLP60/TRI/LG - 60000 BTU - 17.6 Kw *)	WBCL005257	<p>All Compressors are Rotary Scroll except :</p> <p>*) Rotary Compressors Goldstar, Mitsubishi.</p> <p>**) All Rotary Compressor units are not available in cool only version. Standard delivery = inclusive reversed cycle option.</p>
WBCLP72/TRI/LG - 72000 BTU - 21.1 Kw *)	WBCL005258	
WBCLP90/TRI/LG - 90000 BTU - 26.4 Kw *)	WBCL005259	
WBCLP108/TRI/CI - 108000 BTU - 31.7 Kw	WBCL005250	
WBCLP126/TRI/CI - 126000 BTU - 37 Kw	WBCL005251	
WBCLP144/TRI/CI - 144000 BTU - 42.2 Kw	WBCL005252	
WBCLP180/TRI/CI - 180000 BTU - 52.8 Kw	WBCL005253	
WBCLP216/TRI/CI - 216000 BTU - 63.3 Kw	WBCL005254	
WBCLP252/TRI/CI - 252000 BTU - 73.8 Kw	WBCL005255	
Reversible Option **)	WBCL005256	

4 COMPRESSOR MODULES - QUATRO/CI - INDEPENDENT Evaporators/Condensers

WBCLP100/D LG - MINI QUATTRO - 29 Kw	WBCL005490
WBCLP120/D LG - MINI QUATTRO - 35 Kw	WBCL005491
WBCLP240/QUATTRO - 240000 BTU - 70 Kw	WBCL005503
WBCLP288/QUATTRO - 288000 BTU - 85 Kw	WBCL005504
WBCLP336/QUATTRO - 336000 BTU - 99 Kw	WBCL005505
WBCLP384/QUATTRO - 384000 BTU - 112Kw	WBCL005506
WBCLP448/QUATTRO - 448000 BTU - 132Kw	WBCL005507
WBCLP504/QUATTRO - 504000 BTU - 148Kw	WBCL005508
WBCLP572/QUATTRO - 572000 BTU - 168Kw	WBCL005509
Reversible Option	WBCL005500

between the central unit and the air-handlers. This mixed water/glycol circuit is maintained at approx. +4° C.

All Webasto chiller units are equipped with high efficiency multi-plate exchangers.

Temperature regulation of the central chiller unit only concerns the water temperature regardless of the number of active air-handlers.

Air-handlers/blowers can therefore be slowed down or even completely stopped without any incidence for the normal operation of the central chiller unit.

By slowing down blower speed or stopping selected air-handlers altogether, effective capacity transfer to the other active air-handlers is obtained.

This allows to install air-handler over-capacity in specific locations to cope with particularly difficult conditions (wheelhouse with excessive glass area, etc.).

VOLTAGE - FREQUENCY

All Scroll/Rotary compressor units are dual-frequency 50/60 Hz; when running under 60Hz cooling capacity is increased by approx. 10%.

400 V - 3 PHASE

As from 30000 BTU, all single compressor as well as the multi-compressor units can be delivered in 3 ph 400V - 50/60 Hz (Scroll) .

Other Voltages such as 208 - 3 Phase 60Hz can also be delivered for certain models (please consult).

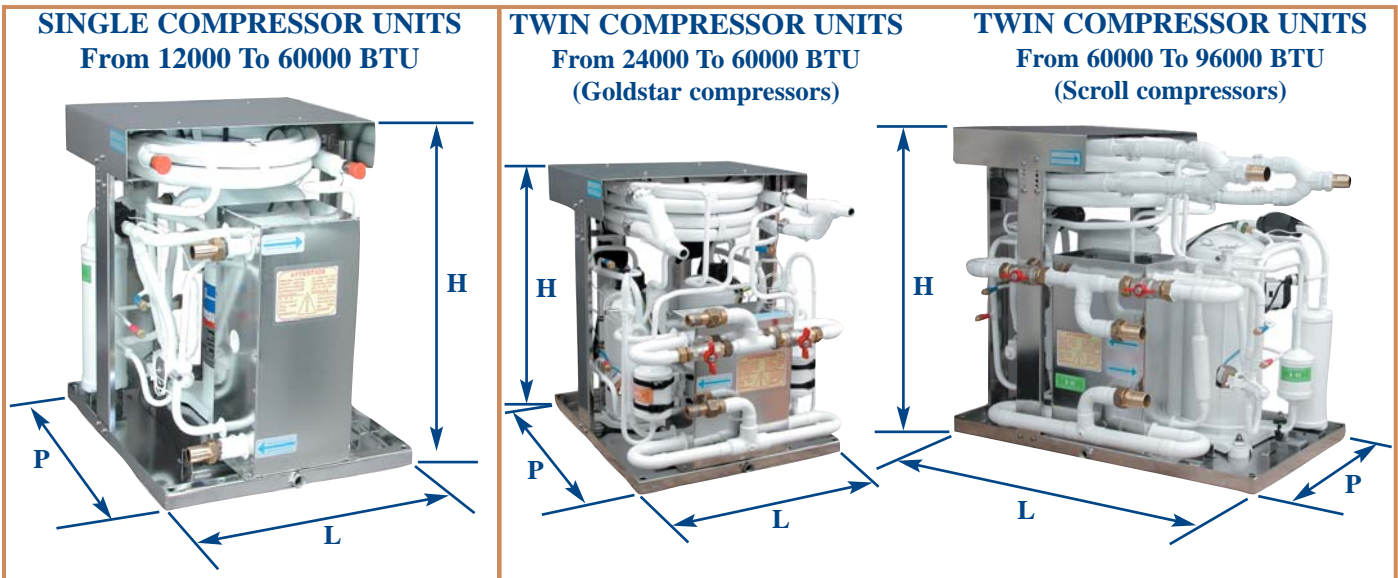

TRI COMPRESSOR UNITS - From 60000 To 252000 BTU

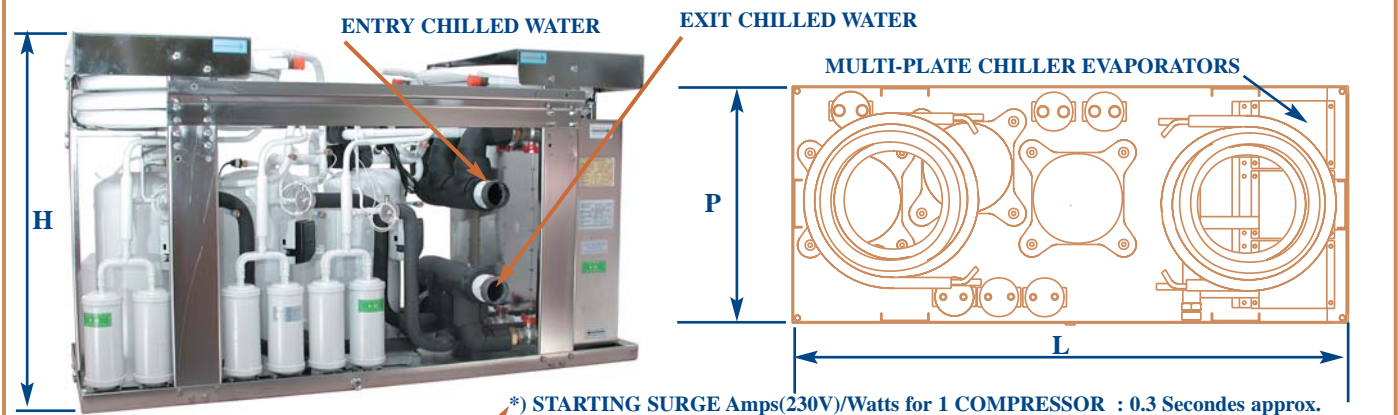

*) STARTING SURGE Amps(230V)/Watts for 1 COMPRESSOR : 0.3 Secondes approx.

MODEL	Voltage/Phase	Amps/Watt's Run./ Start	Refrigerant	BTU/KW	Net Weight	Cool. Pump	Diam. Chil/Water	Dimensions L x P x H
WBPC12/LG	230/115V - 1	4.2A/9A	R22/R407C	12000/3.5	35 Kgs	WB350	15 mm	345 x 370 x 380
WBPC16/LG	230/115V - 1	5.2A/11A	R22/R407C	16000/4.7	42 Kgs	WB350	15 mm	345 x 370 x 390
WBPC20/LG	230V - 1	6.3A/14A	R407C	20000/5.8	45 Kgs	WB350	15 mm	345 x 370 x 420
WBPC24/LG	230V - 1	7.5A/18A	R407C	24000/7	50 Kgs	WB350	20 mm	345 x 370 x 450
WBPC30/LG	230V - 1	9A/21A	R407C	30000/8.8	60 Kgs	WB1000	20 mm	345 x 370 x 480
WBPC30/S	230/400V - 1/3	2200/5000	R22/R407C	30000/8.8	65 Kgs	WB1000	20 mm	415 x 480 x 480
WBPC36/S	230/400V - 1/3	2650/5600	R22/R407C	36000/10.5	70 Kgs	WB1000	20 mm	415 x 480 x 480
WBPC42/S	230/400V - 1/3	3000/7300	R22/R407C	42000/12.3	75 Kgs	WB1000	20 mm	415 x 480 x 500
WBPC48/S	230/400V - 1/3	3450/9200	R22/R407C	48000/14	75 Kgs	WB1000	20 mm	415 x 480 x 500
WBPC60/S	208/400V - 3	4400/9800	R22/R407C	60000/17.6	80 Kgs	WB1500	25 mm	415 x 480 x 500
WBPC24 TwG	230/115V- 1	8.4A/9A	R407C	24000/7	70 Kgs	WB350	20 mm	415 x 480 x 500
WBPC32 TwG	230/115V- 1	10.4A/11A	R407C	32000/9.4	75 Kgs	WB1000	20 mm	415 x 480 x 500
WBPC40 TwG	230V - 1	12.6A/14A	R407C	40000/11.6	75 Kgs	WB1000	20 mm	415 x 480 x 500
WBPC50 TwG	230V - 1	15A/18A	R407C	50000/14.6	85 Kgs	WB1500	25 mm	415 x 480 x 540
WBPC60 TwG	230V - 1	18A/21A	R407C	60000/17.6	90 Kgs	WB1500	25 mm	415 x 480 x 590
WBPC60 TwS	230/400V - 1/3	4400/5000	R22/R407C	60000/17.6	95 Kgs	WB1500	25 mm	680 x 415 x 620
WBPC72 TwS	230/400V - 1/3	5300/5600	R22/R407C	72000/21.1	100 Kgs	WB2500	25 mm	680 x 415 x 620
WBPC84 TwS	230/400V - 1/3	6000/7300	R22/R407C	84000/24.6	105 Kgs	WB2500	32 mm	680 x 415 x 680
WBPC96 TwS	230/400V - 1/3	6900/9200	R22/R407C	96000/28.2	130 Kgs	WB3000	32 mm	680 x 415 x 680
WBPC60/Tri/LG	230V - 1	19A/14A	R407C	60000/17.6	120 Kgs	WB1500	25 mm	1050 x 510 x 620
WBPC72/Tri/LG	230V - 1	22.5A/18A	R407C	72000/21.1	130 Kgs	WB2500	25 mm	1050 x 510 x 650
WBPC90/Tri/LG	230V - 1	27A/21A	R407C	90000/26.4	140 Kgs	WB3000	32 mm	1050 x 510 x 650
WBPC108 Tri	230/400V - 1/3	8000/5600	R22/R407C	108000/31.6	160 Kgs	WB3000	36 mm	1320 x 510 x 720
WBPC126 Tri	230/400V - 1/3	9000/7300	R22/R407C	126000/37	180 Kgs	WB3000	36 mm	1320 x 510 x 720
WBPC144 Tri	230/400V - 1/3	10350/9200	R22/R407C	144000/42.2	190 Kgs	WB3000	42 mm	1320 x 510 x 720
WBPC180 Tri	208/400V - 3	13200/9800	R22/R407C	180000/52.7	210 Kgs	WB5500	42 mm	1320 x 510 x 780
WBPC216 Tri	208/400V - 3	16500/14500	R22/R407C	216000/63.3	250 Kgs	WB5500	48 mm	1320 x 510 x 780
WBPC252 Tri	208/400V - 3	18900/16500	R22/R407C	252000/73.9	260 Kgs	WB5500	48 mm	1320 x 510 x 780

ATT : LG = LG/TwLG/TriLG = Rotary Compressors - S/TwS = Scroll Compressors

4 COMPRESSOR UNITS - QUATRO/CI - From 100000 to 572000 BTU

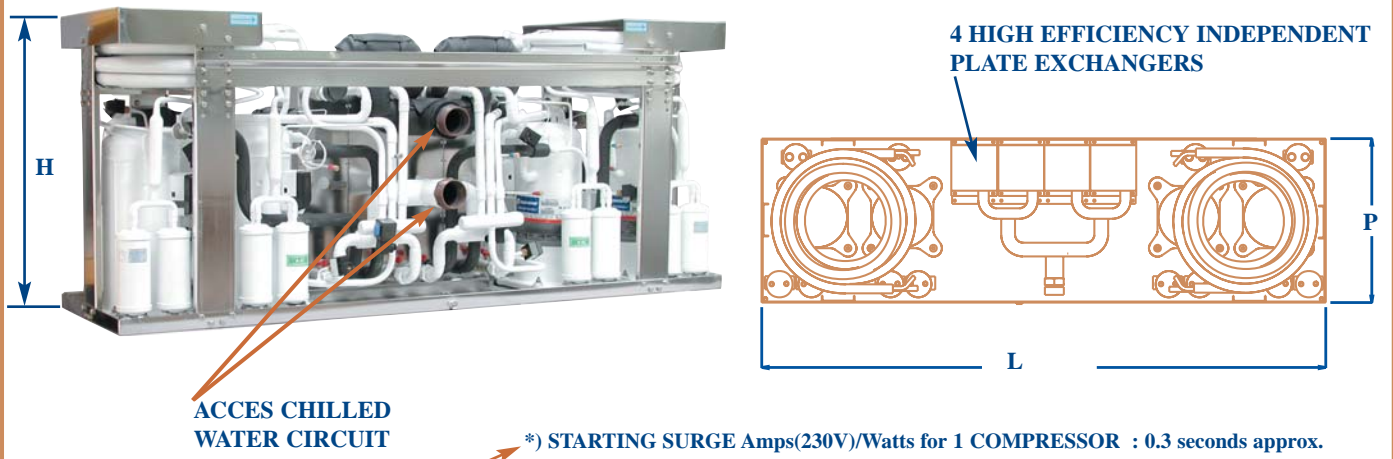

ACCES CHILLED WATER CIRCUIT

*) STARTING SURGE Amps(230V)/Watts for 1 COMPRESSOR : 0.3 seconds approx.

MODEL	Voltage/Ph.	Run/Start	Refrigerant	Btu/Kw	Net Weight	Cool. Pump	Diam. ChW	L x P x H (mm)
WBCP100 Qtr	230V - 1Ph	30A/18A	R407C	100000/29.3	175 Kgs	1xWB3000	32 mm	1050 x 510 x 650
WBCP120 Qtr	230V - 1Ph	36A/21A	R407C	120000/35.2	185 Kgs	1xWB3000	32 mm	1050 x 510 x 650
WBCP240 Qtr	208/400V- 3	17500/9800	R22/R407C	240000/70	270 Kgs	1xWB5500	54 mm	1720 x 500 x 720
WBCP288 Qtr	208/400V- 3	22000/14500	R22/R407C	288000/84.4	350 Kgs	1xWB5500	63 mm	1720 x 500 x 780
WBCP336 Qtr	208/400V- 3	25000/16500	R22/R407C	336000/98.5	350 Kgs	1xWB5500	63 mm	1720 x 500 x 780
WBCP384 Qtr	400V - 3	27200/18000	R22/R407C	384000/113	450 Kgs	1xWB5500	75 mm	2100 x 600 x 800
WBCP448 Qtr	400V - 3	30400/20000	R22/R407C	448000/132	670 Kgs	1xWB7400	82 mm	2100 x 600 x 850
WBCP504 Qtr	400V - 3	34200/22500	R22/R407C	504000/150	670 Kgs	1xWB7400	82 mm	2100 x 600 x 900
WBCP572 Qtr	400V - 3	38000/25000	R22/R407C	572000/168	725 Kgs	1xWB7400	82 mm	2100 x 600 x 990

FRESH-AIR UNITS 24000 AND 48000 BTU / AIR-EXTRACTION AIR UNITS

Functioning Principles :

- 1) Regulate fresh-air entry into the vessel by temperature differential outside / inside + combined air extraction control.
- 2) Basic regulation by adjustable temperature differential outside/inside with programma-

FRESHAIR24 - FRESH-AIR 24000 BTU - LAT. VIEW

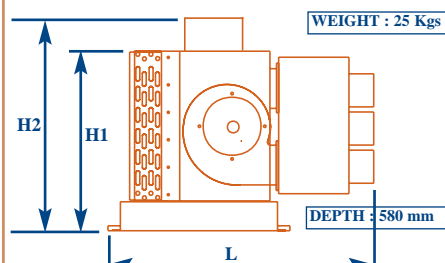

FRESHAIR48 - FRESH-AIR 48000 BTU - LAT. VIEW

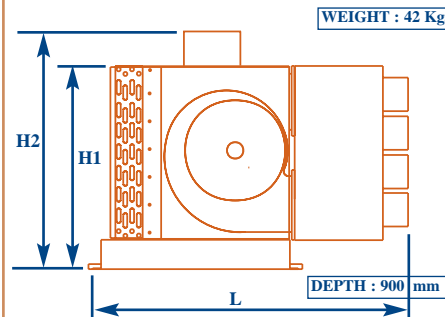

EXTRACT24 - AIR EXTRACTION UNIT - LAT. VIEW

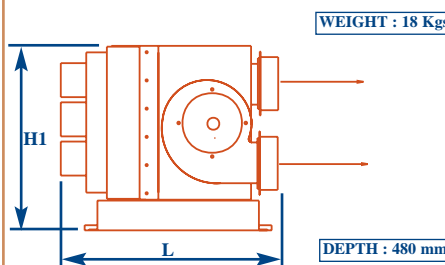

DIGITAL DISPLAY <FRESH-AIR CONTROL>



- 3) Provision for 2 stage integrated reheat (AC electrical)
- 4) Electronic controller provides 2 separate blower outlets : 1 for fresh-air input and 1 for extraction air out.
- 5) Different speed settings possible for both outlets. All speed settings including max. speed completely re-programmable. Manual only speed control possible.
- 5) Aldes flow regulators allow easy and precise balancing of outputs per volume.
- 6) Integrated Solenoid 3 way valve control
- 7) Special start-up procedure to eliminate residual moisture in system.
- 8) Three temperature read-outs : - outside air temperature - chilled water circuit temp. - treated air input temperature (after chiller coil + reheat)

DIMENSIONS :	L	H1	H2
FRESHAIR24	700	435	560
FRESHAIR48	780	485	610
FRESHAIR 2x24	840	485	610
EXTRACTAIR24	515	435	

Models Available :

FRESH-AIR MAKE-UP :	Réf. WB
FreshAir24-24KBtu/1050m3/h	WBCL005241
FreshAir24-24KBtu/1800m3/h	WBCL005242
FreshAir48-48KBtu/1800m3/h	WBCL005240
FreshAir 2x24KBtu/1800m3/h	WBCL000218
AIR EXTRACTION :	
Extract24 - 1050 m3/hr	WBCL000216
FreshAir Electronic Control	WBCL000217

FRESHAIR24 UNIT - 24000 BTU



Webasto - AIR-HANDLERS

COMPACT SERIES AIR-HANDLERS

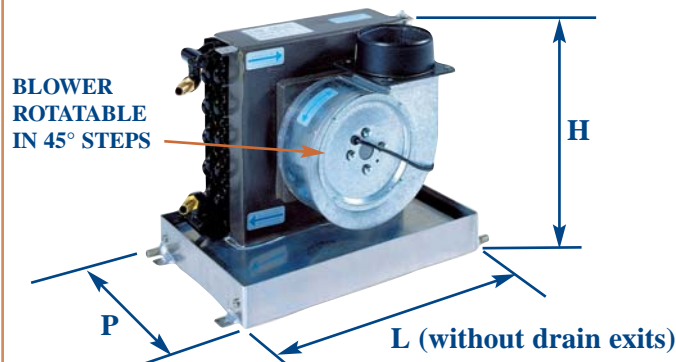

HORIZONTAL CROSS-FLOW AIR-HANDLERS - TAN/H

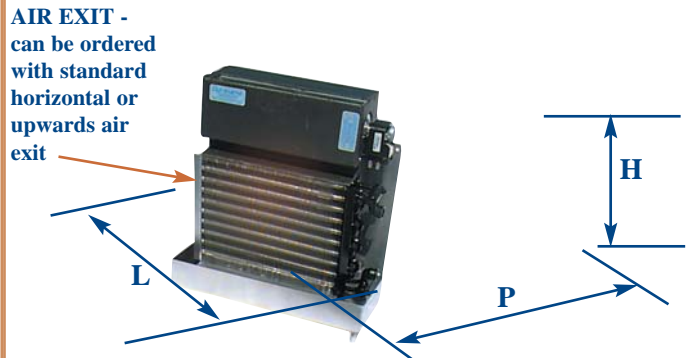

SLIMLINE AIR-HANDLERS (Centrifugal Blowers)

Left : Slim-Line 24000 BTU

Right : Slim-line 4500 to 20000 BTU

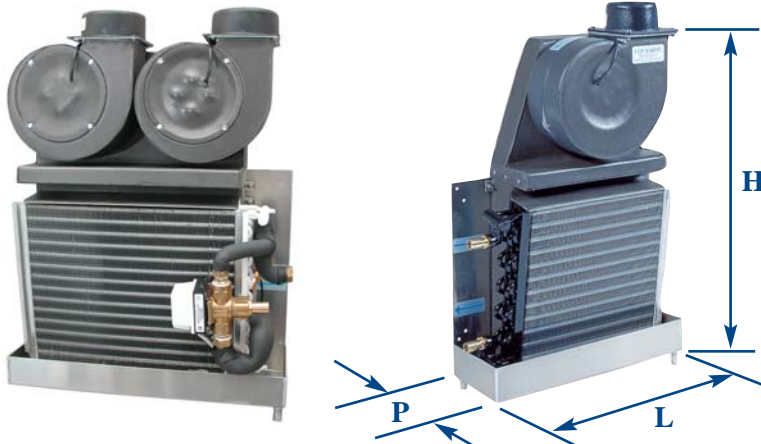

Vertical CROSS-FLOW AIR-HANDLERS - TAN/V

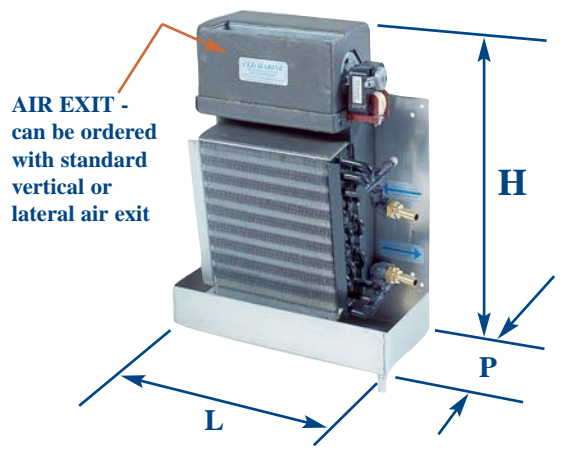

AIR-HANDLERS - SPECIFICATIONS - DIMENSIONS - BLOWER CAPACITIES

MODEL	CLD Ref. 230V	CLD Ref. 115V	Air Flow m3/hr	Running Watts	Diam. Hose Ring/mm	NetWeight Kgs	Diam. Chil/Water	BTU/Kw	Dimensions H x L X P
Comp. 4500	WBCL000744	WBCL006300	275	80	100	5	16	4500/1.3	265 x 340 x 260
Comp. 6000	WBCL000745	WBCL006301	275	80	100	7.5	16	6000/1.7	265 x 400 x 260
Comp. 9000	WBCL000746	WBCL006302	430	130	100	9	16	9000/2.6	295 x 430 x 300
Comp. 12000	WBCL000747	WBCL006303	500	150	125	9.5	16	12000/3.5	345 x 430 x 300
Comp. 16000	WBCL000748	WBCL006304	625	200	125	12.5	16	16000/4.6	345 x 505 x 300
Comp. 20000	WBCL000790	WBCL006305	625	200	125/150	14	20	20000/5.6	405 x 505 x 300
Comp. 24000	WBCL000329	WBCL006306	2 x 500	300	2 x 125	20	20	24000/7	405 x 550 x 300
Comp. 30000	WBCL000330		2 x 550	400	2 x 125	24	20	30000/8.8	405 x 650 x 320
Comp. 48000	WBCL000789		2 x 900	620	2 x 150	40	20	48000/14	450 x 960 x 350
TAN 4000/H	WBCL000750	WBCL006313	150	30	180 x 40	5	16	4000/1.1	170 x 305 x 405
TAN 6000/H	WBCL000752	WBCL006312	190	40	240 x 40	7	16	6000/1.7	170 x 360 x 405
TAN 9000/H	WBCL000753	WBCL006311	250	46	302 x 40	8	16	9000/2.6	170 x 410 x 440
TAN 12000/H	WBCL000765	WBCL006310	250	46	302 x 40	9	16	12000/3.5	170 x 410 x 495
SlimL 4500/V	WBCL000740	WBCL006350	275	80	100	6.5	16	4500/1.3	465 x 300 x 145
SlimL 6000/V	WBCL000741	WBCL006351	275	80	100	8	16	6000/1.7	465 x 355 x 145
SlimL 9000/V	WBCL000742	WBCL006352	430	130	100	10	16	9000/2.6	550 x 410 x 155
SlimL 12000/V	WBCL000743	WBCL006353	500	150	125	11	16	12000/3.5	615 x 410 x 155
SlimL 16000/V	WBCL000791	WBCL006360	625	200	125	15	16	16000/4.6	620 x 470 x 165
SlimL 20000/V	WBCL000792	WBCL006361	625	200	125	16	20	20000/5.6	670 x 470 x 165
SlimL 24000/V	WBCL000793	WBCL006362	2 x 500	300	2 x 125	30	20	24000/7	710 x 570 x 215
SlimL 4500/H	WBCL000950	WBCL006370	275	80	100	7	16	4500/1.3	170 x 305 x 470
SlimL 6000/H	WBCL000951	WBCL006371	275	80	100	8.5	16	6000/1.7	170 x 360 x 470
SlimL 9000/H	WBCL000952	WBCL006372	430	130	100	10	16	9000/2.6	170 x 410 x 560
SlimL 12000/H	WBCL000953	WBCL006373	500	150	125	11	16	12000/3.5	170 x 410 x 625
SlimL 16000/H	WBCL000954	WBCL006374	625	200	125	15	16	16000/4.6	185 x 470 x 635
SlimL 20000/H	WBCL000955	WBCL006375	625	200	125	16	20	20000/5.6	185 x 470 x 680
SlimL 24000/H	WBCL000956	WBCL006376	2 x 500	300	2 x 125	30	20	24000/7	200 x 570 x 730
TAN 4000/V	WBCL000760	WBCL006354	150	30	180 x 40	5	15	4000/1.1	410 x 305 x 150
TAN 6000/V	WBCL000762	WBCL006355	190	40	240 x 40	7.5	15	6000/1.7	410 x 360 x 150
TAN 9000/V	WBCL000763	WBCL006356	250	46	302 x 40	8.5	16	9000/2.6	440 x 410 x 155
TAN 12000/V	WBCL000766	WBCL006357	250	46	302 x 40	9.5	16	12000/3.5	480 x 410 x 155

QUICK BTU CALCULATION GUIDE & AIR DUCTING

To quickly calculate your BTU needs per volume, use the table below - be carefull with highly exposed wheelhouse areas. For extreme climatic conditions such as the Persian Gulf Area where sea-water temperatures frequently rise above 32° C and outside tempaures to above 40° C, add approx. 25/30% over-capacity.

VOLUME DESCRIPTION	BTU RATING PER M3	To obtain Total BTU's per Volume, multiply total volume by BTU rating as given to the left. Example : Sleeping Cabin : Length : 3.50 m Width : 2.75 m Average Height : 2.10 m Total BTU's needed : 3.5 x 2.75 x 2.1 x 400 = 8000 BTU
Below Deck Cabins - Portholes Only	400	
Above Deck Cabins - Average Glass Area	500	
Above Deck Dining Room/Salon Area - Average Glass Area	600	
Above Deck Wheelhouse Area - Generous Glass Area	750	
Usefull Info : 1000 BTU = 0.2934 Kw		

AIR DUCTING - VENTILATION

1) MINIMUM AIR-GRILLE SECTIONS

To obtain acceptable noise levels at max. blower speed minimum requirements for grille and ducts sections should be observed. Also the size of the transition box behind the supply air-grille is important. See table here-under :

models) can be rotated through 45° steps so as to obtain a straight-line outlet from the blower. This facility should be used whenever possible.

3) RETURN GRILLE OFFSET

It is best to avoid placing a return air grille directly opposite the finned coil surface of an air-handler. This will inevitably allow propagation of direct blower-motor noise through the grille.
Always try to offset the grille so as to chicane

smoothness.

For very long duct sections preference should be given to smooth bore ducts (in PVC for example) which offer a far greater smoothness than flexible spiral type ducting and therefore will greatly reduce internal friction.

For very short lengths non-insulated ducts may possibly be used. Over greater lengths it is advisable to use insulated type ducts to avoid condensation on the outside of the air-

AIR/HANDLER-WBCC MODEL	SUPPLY AIR GRILLE MODEL/ SECTION cm ²		RETURN AIR GRILLE MODEL/SECTION cm ²		DUCT DIAM. <2M DUCT LENGTH	DUCT DIAM. >2M DUCT LEN.
	4000/4500 BTU	1 x 8x4"	150 cm ²	1 x 12x5"	325 cm ²	80 mm
6000 BTU	1 x 10x4"	190 cm ²	1 x 11x8"	490 cm ²	100 mm	125 mm
9000 BTU	1 x 12x4"	235 cm ²	1 x 11x8"	490 cm ²	100 mm	125 mm
12000 BTU	1 x 10x5"	250 cm ²	1 x 14x7"	550 cm ² or	125 mm	150 mm
16000 BTU or	1 x 12x6"	390 cm ²	1 x 14x10"	800 cm ²	125 mm	150 mm
16000 BTU	2 x 10x4"	380 cm ²			125 mm	150 mm
24000 BTU	2 x 10x5"	500 cm ²	1 x 14x12"	1000 cm ²	2 x 125 mm	2 x 150 mm
30000 BTU	2 x 12x5"	650 cm ²	2 x 14x10"	1600 cm ²	2 x 125 mm	2 x 150 mm

NB : For duct lengths over 2 ml, it may be possible to use the nominal duct diameter (for example 100 mm - 6000 BTU model), if instead of spiral type flexible ducts, smooth-bore interior ducts, are used.

2) BLOWER OUTLETS (Drawing here-under)

90° turns with flexible ducts directly from blower outlets should be avoided at all costs as they introduce severe restrictions in the air-flow.

All WB blowers (except on 24000 BTU

the return air to the coil inlet. This will lower direct noise propagation in a significant manner.

4) DUCT TYPE

Flexible air-ducts should be of high quality with sufficiently strong steel spiral reinforcement to avoid accidental crushing. Spiral type ducts should be extended to their maximum possible length for max. interior

ducts.

5) BIG LUXURY YACHTS

In general requirments for megayachts and big luxury vessels are even more stringent than the table here-above.

These special requirements can be obtained from WB on request.

ROTATABLE BLOWER OUTLETS

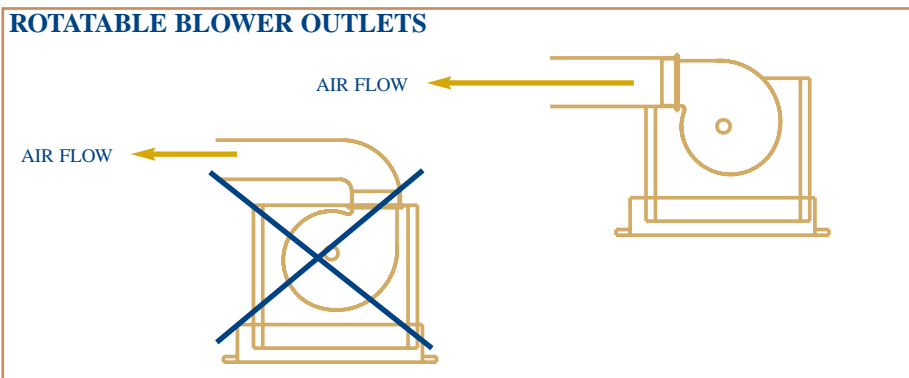

AIR TRANSITION BOXES - BEHIND SUPPLY AIR GRILLES



DUCT DIAM.	MIN. VALUE OF "H"
80 mm	100 mm
100 mm	120 mm
125 mm	140 mm
150 mm	165 mm

CONTROLS FOR CHILLED WATER SYSTEMS - WBCP SERIES

SCHEMATICS :

Standard Control Box inclusive TECC electronic controller card - standard delivery for all WBCP**/D references

BOX Dim.	12/24D	24/96D	100/572D
H =	225	245	344
L =	140	344	484
P =	128	154	164

Digital Control Panel *)

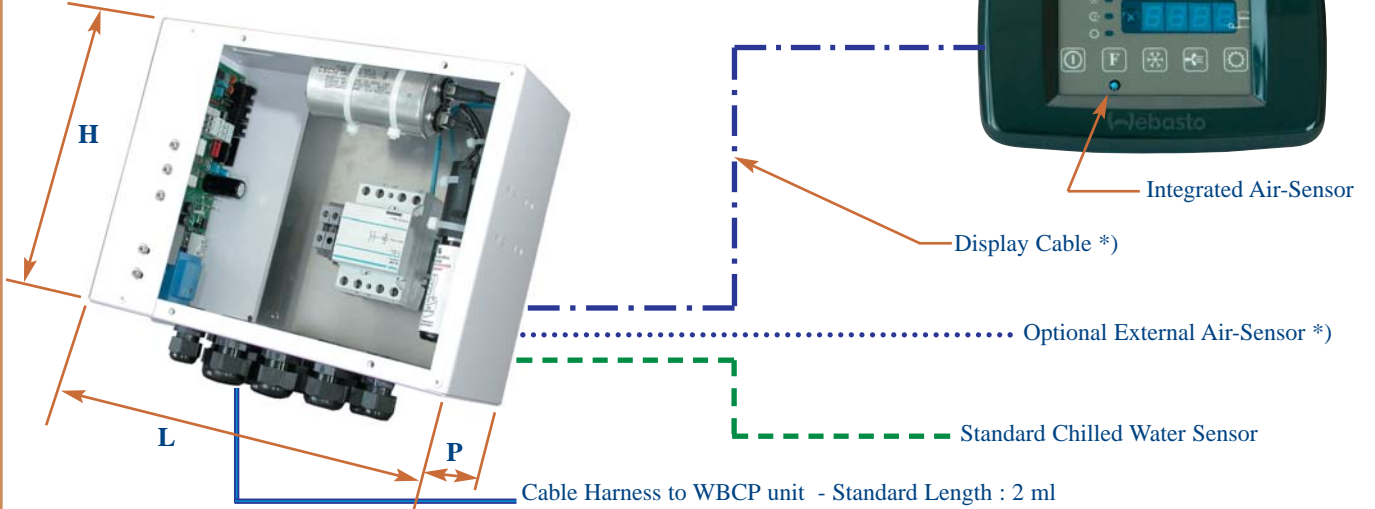

NB : All components marked *) should be ordered separately - see reference table here-under to choose specific lengths

FUNCTIONING PRINCIPLES

The complete Chiller Digital Control System includes a TECC controller card in alu box + Digital Chiller Control panel + cables and accessories. The Chiller Control panel allows direct read-out of chilled water temperature at the exit of the chiller condensing unit.

In addition to the standard available modes and information, the following features can also be accessed :

- key-board control, cool cycle only mode
- key-board control, heat cycle only mode
- key-board control, automatic cycle switching cool/heat
- direct control over external heat-source integrated in the chilled water circuit
- calibration of temperature read-outs
- fine tuning of blower speed settings
- choice between thermostatic and continuous blower control - 0 position blower control = blower halt
- choice between internal and external air sensor
- all TECC cards can control 4 chiller units with staged compressor start-up
- direct control chilled water circulation pump
- modification of the high and low set- points chilled water circuit temperature
- modification low-voltage cut-out settings
- Manual or automatic compressor rotation to equalize running hours
- Direct control over each compressor running status directly from digital display
- all safety controls are micro-processor controlled with direct display of all error codes.

EASY CONNECTIONS :

- all cables connections by phone type

DIGITAL DISPLAY : OPERATION AND KEY FUNCTIONS :



The 2004 Digital Displays are backwards compatible with the 2000 series

CHILLER CONTROLS, DISPLAYS and ACCESSORIES

	WB Reference
Digital Display <Chiller Control> - 2004 Series with WB Bezel	WBCL000827
TECC Controller card 230V AC - V2 Series - 1/2 Compressors	WBCL000384
TECC Controller card 230V AC - V2 Series - 3/4 Compressors	WBCL000387
Aluminium electrical box - Twin compressor systems	WBCL000822
Aluminium electrical box - tri/quatro compressor systems	WBCL000825
Chilled water temperature sensor with 3 m cable	WBCL000368
Chilled water temperature sensor with 6 m cable	WBCL000369
Fuse Kit for TECC cards	WBCL000367
TECC Controller Card 115V AC - V2 Series - 1/2 Compressors	WBCL000845
TECC Controller Card 115V AC - V2 Series - 3/4 Compressors.....	WBCL000846
Softstart Tri 400V - Model MCI-15C - 15A	WBCL000830
Softstart Tri 400V - Model MCI-25C - 30A	WBCL000831
TECC V3 - Controller Card - 230V - 2006 series - 2 Compr.	WBCL000864
TECC V3 - Controller Card - 230V - 2006 series - 3/4 Compr.	WBCL000866
TECC V3 - Controller Card - 115V - 2006 series - 2 Compr.	WBCL000865
TECC V3 - Controller Card - 115V - 2006 series - 3/4 Compr.	WBCL000867

NB - For all display cables and external air sensors - see page 6 .

- modular jacks
 - installation by adhesive strips or screws
- COLOUR AVAILABLE :**

- Grey/Blue
- LAST SETTINGS RETAINED :**
Non-volatile memory retains last settings

CHILLED WATER SYSTEMS - CABIN BLOWER CONTROLS

CABIN BLOWER CONTROLS - SCHEMATICS

Standard Electrical Box for CAB230 Electronic Controller

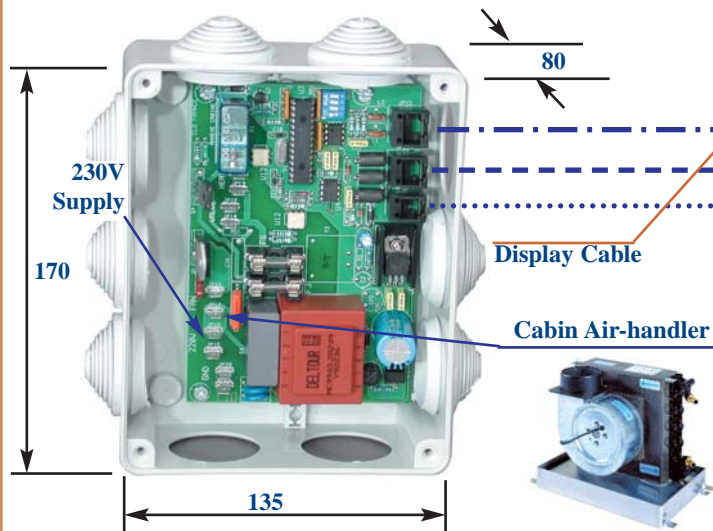

Standard Digital Cabin Control Package CAB includes :
 - 230/115V CAB controller in plastic box
 - 4 m display cable/ 3m Chilled Water Temp. sensor
 - Digital Display <AIR CONTROL>

NB : All components marked *) should be ordered separately - see reference table here-under to choose specific lengths

WEBASTO proposes a very complete choice of cabin blower controls :

- 1) The MTH system, a simple mechanical thermostat without blower speed control
- 2) Mechanical Thermostat with integrated 3 speed blower control.
- 3) Digital cabin control with CAB230 controller + <AIR CONTROL> digital display + chilled water temp. sensor

1) MTH - Mechanical Thermostat

The mechanical thermostat is reversible by a winter/summer selector. When set-point is obtained, the thermostat will stop blower operation.

2A) Belux Mechanical Thermostat + 3 Speed Blower Control

Based on an extended MTH thermostat + 3 speed selector + On/Off switch. See photo bottom left.

2B) Plana (Vimar) Mech. Thermostat + 3 Speed Blower Control

Based on the modular Plana series by Vimar with the same features as 2A

3) Standard Digital Cabin Control (CAB230)

This control system includes automatic

cycle recognition by the chilled water temperature sensor attached to the entry of the chilled water air-handler.

The CAB controller card includes most of the features found on the TECC master controller such as :

- direct chilled water temperature read-out
- 5 manual speed settings + 1 automatic by temperature differential
- automatic blanking of display
- calibration of all speed settings
- up to 4 blowers on 1 CAB card

- direct set-point modification
- choice between internal and external air temperature sensor
- thermostatic or continuous blower operation
- access code to programmable functions
- visual alarm when water temperature at entry of air-handler is incompatible with set-point as requested.

The CAB standard digital control system is available in 230V AC and 115V AC.

PLANA (VIMAR) MECHANICAL THERMOSTAT + 3 SPEED BLOWER CONTROL

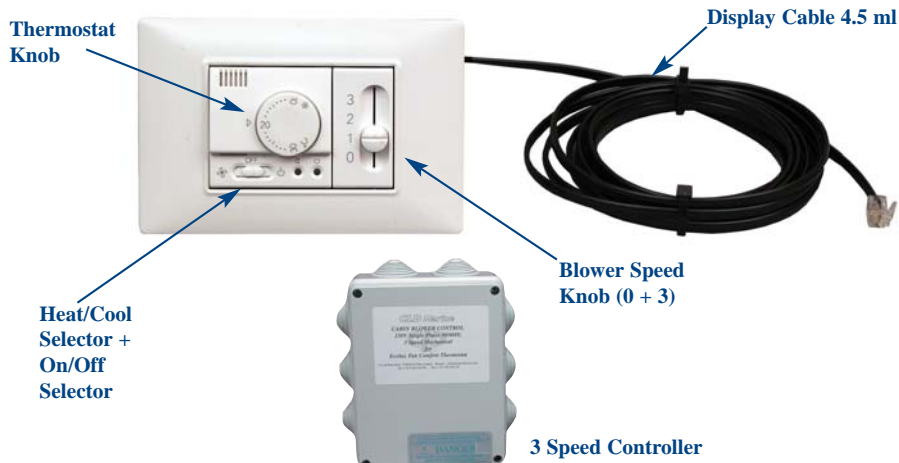

BELUX MECHANICAL THERMOSTAT + 3 SPEED CONTRL

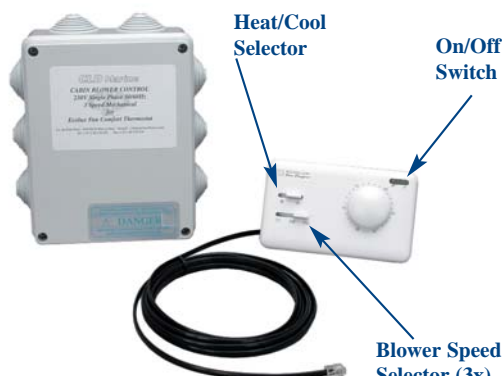

WB CABIN CONTROLS + ACCESSORIES

Complete Digital Cabin Control - CAB230V - 2004 Series	WBCL000373
Complete Digital Cabin Control - CAB115V - 2004 Series	WBCL000850
MTH Thermostat230/115V without Blower speed control	WBCL000362
MTH Thermostat 230V with integrated 3 speed Blower Ctrl ..	WBCL000392
Electronic Controller CAB230 V3 - 230V - 2005/6 Series	WBCL000860
Electronic 3 speed controller 230V for ref. WBCL000392	WBCL000376
Electronic Controller CAB115 V3 - 2005/6 Series	WBCL000861
MTH Thermostat 115V with integrated 3 speed Blower Ctrl ..	WBCL000851
Electronic 3 speed controller card 115V for ref. WBCL000851	WBCL000853
Plana (Vimar) Thermostat 230V with 3 speed control	WBCL000394

All 2004 Digital panels are backwards compatible with the 2000 Series.

NB - Water temp. sensors - see page 12 - Air Sensors : page 6

Webasto - MARINE PUMPS

MAGNETIC DRIVE PUMPS - IWAKI

PUMPS WB250 - 1000 & 1500 - 2000

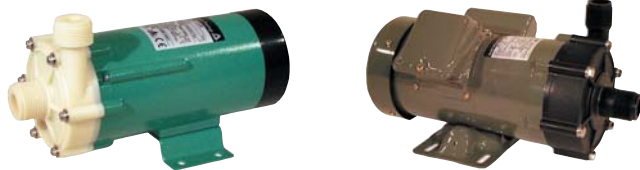

PUMPS WB3500 To 9800

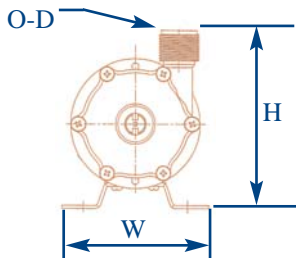
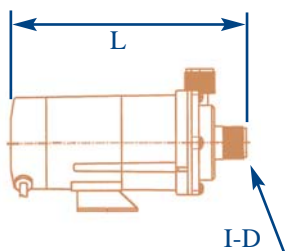

SELF-PRIMING - WB4000/5600/8000/10500



MECHANICAL DRIVE PUMPS - CALPEDA

PUMPS WB2500 To 7500 *)



*) Model WB7500 can only be used for chiller water circulation, not for sea-water cooling.

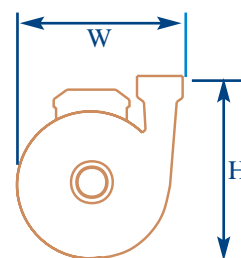
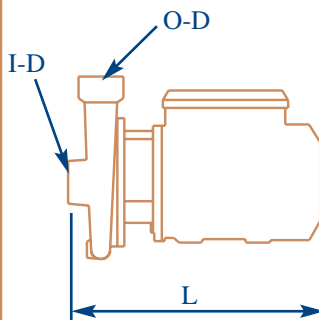

PUMPS - SPECIFICATIONS - WB REFERENCE CODES

MODEL	Webasto Ref. 230V	Webasto Ref. 115V	Output L/Min	Running /Watts	Diam. I/O		Weight/ Kgs	BTU Max. Chil/Loop	BTU Max. Condensing	Dimensions mm L X W x H
Iwaki 50/60 h					I-D	O-D				
WB250	WBCL001104	WBCL001301	15	30	5/8"	5/8"	2	N/A	12000	198 x 95 x 114
WB350	WBCL001105	WBCL001302	25	45	5/8"	5/8"	2.5	N/A	24000	205 x 95 x 115
WB1000	WBCL001106	WBCL001303	48	145	3/4"	3/4"	4.5	24000	48000	250 x 120 x 130
WB1500	WBCL001107	WBCL001304	85	300	1"	1"	7.5	60000	72000	250 x 156 x 168
WB2000	WBCL001108	400V Tri	115	400	1"	1"	10	84000	96000	315 x 156 x 168
WB3500	WBCL001109	WBCL001170	225	450	1.25"	1.25"	14	144000	144000	375 x 140 x 210
WB5500	WBCL001110	WBCL001171	335	750	1.25"	1.25"	22	250000	300000	495 x 160 x 248
Calpeda 50hz										
WB2500	WBCL001130		150	350	1"	1"	9.5	84000	108000	263 x 154 x 158
WB3000	WBCL001131		185	450	1"	1"	9.8	100000	144000	263 x 171 x 190
WB5500	WBCL001132	WBCL001172	320	750	1.25"	1.25"	20	250000	336000	380 x 193 x 240
WB7500 *)		WBCL001136	450	1500	2"	1.25"	23	450000	N/A	382 x 190 x 250
WB4000 #)	WBCL001160	WBCL001161	200	370	1.5"	2"	9		144000	498 x 215 x 270
WB5600 #)	WBCL001162	WBCL001163	300	750	1.5"	2"	12.2		300000	530 x 215 x 270
WB8000 #)		WBCL001164	450	1100	2"	2"	19		450000	592 x 215 x 302
WB10500 #)		WBCL001165	650	2200	2"	2"	21		650000	592 x 215 x 302
Calpeda 60hz										
WB2500	WBCL001133		150	350	1"	1"	9.5	84000	108000	263 x 154 x 158
WB3000	WBCL001134		185	450	1"	1"	9.8	100000	144000	263 x 171 x 190
WB5500	WBCL001135		320	750	1.25"	1.25"	20	250000	325000	380 x 193 x 240
WB7500 *)		WBCL001137	450	1500	2"	1.25"	23	450000	N/A	382 x 190 x 250
Iwaki 50 Hz										
WB7400		WBCL001138	420	2200	2"	1.5"	25	450000	500000	533 x 260 x 249
WB9800		WBCL001139	600	4000	2"	1.5"	32	520000	600000	560 x 260 x 270

#) = SELF-PRIMING SEA-WATER PUMPS

	SELF-PRIMING PUMPS - MODELS 125 / 200	Capacity Litres/Min. WB 125 / WB 200 7 / 12 L/min. L = Length x H = Height x W = Width 195 mm/130 mm/ 130 mm D - diameter inlet/outlet 1/2" - 12.7 mm Model WB125 - 12V WBCL001100 Model WB125 - 24V WBCL001102 Model WB200 - 115/230V - Variable Output ... WBCL001103 Running Watts WB125/WB200 18/25 Watts Weight 1.2 Kg Condensing Cap. BTU's - WB 125 6000 BTU max. Condensing Cap. BTU's - WB 200 16000 BTU max.
---	--	---

SEA WATER & CIRCULATION PUMPS - ACCESSORIES

	SEA WATER STRAINER 5/8" - 3/4"	Capacity US Gallons/hour 350/1000 US Gallons/hr Capacity Litres/Min. 25/50 L/min. For pump models WB250 / WB350-1000 H - height mm 140 mm W - width mm 100 mm D - diameter inlet/outlet 5/8"- 15/21 / 3/4" - 20/27 WB reference 5/8" WBCL001151 WB reference 3/4" WBCL001152 Screen/filter element 1000 Microns WB Screen reference WBCL001154
---	---------------------------------------	--

	SEA WATER STRAINER 1"	Capacity US Gallons/hour 1000 US Gallons/hr Capacity Litres/Min. 50 L/min. For pump models WB1000 TO 2000 H - height mm 290 mm W - width mm 144 mm D - diameter inlet/outlet 1" - 25/32 mm WB reference WBCL001153 Screen/filter element 1000 Microns WB Screen reference WBCL001155
--	------------------------------	---

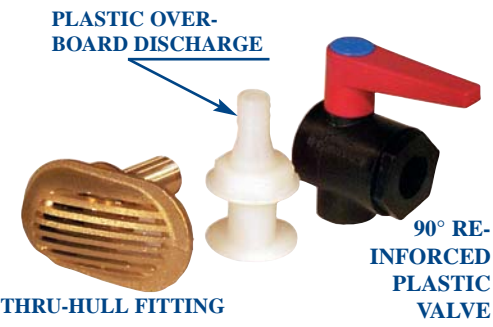
	THRU-HULL KITS 5/8" AND 3/4"	Capacity US Gallons/hour - Litres/min 350/1000 - 25/50 L/min. For pump models WB250 / WB350-1000 D - diameter inlet/outlet - kit 5/8" 5/8"- 15/21 / 1/2" - 12/17 D - diameter inlet/outlet - kit 3/4" 3/4"- 20/27 / 5/8" - 15/21 WB Kit 5/8" - 1 RANDEX 90° Valve WBCL001125 WB Kit 3/4" - 1 RANDEX 90° Valve WBCL001126 WB ref. Kit 5/8" - 2 Randex Valves/Bronze exit.. WBCL001123 WB ref. Kit 3/4" - 2 Randex Valves/Bronze exit.. WBCL001124 WB Kit 5/8" - 1 Nickel Plated Valve..... WBCL001175 WB Kit 3/4" - 1 Nickel Plated Valve WBCL001176 WB Kit 5/8" - 2 Nickel Pl. Valves/Bronze exit WBCL001177 WB Kit 3/4" - 2 Nickel Pl. Valves/Bronze exit WBCL001178 WB Kit 1" - 1 Nickel Pl. Valve/Bronze exit WBCL001179
---	-------------------------------------	--

	AIR-BLEEDER/PRIMER - SUPPLY SIDE (SEA-WATER COOLING PUMPS)	Model 350R (for pumps WB250 et 350) : Tee 3/4" - diam. supply end outlet 1/2" - 12/17 mm WB reference WBCL001118 Model 1000R (for pump WB1000) : Tee 3/4" - diam. supply end outlet 3/4" - 20/27 mm WB reference WBCL001119 Model 2000R (for pump WB1500 to 2500) : Tee 1" - diam. supply end outlet 3/4" - 20/27 mm WB reference WBCL001120
---	---	--

	PRIMING TEE - SUCTION SIDE - CHILLED WATER CIRCULATION PUMPS	Model 1000S (for pump WB1000) : Tee 3/4" - diam. shut-off valve outlet 5/8" - 15/21 mm WB reference WBCL001121 Model 2000S (pumps WB1500 to WB2500) : Tee 1" - diam. shut-off valve outlet 3/4" - 20/27 mm WB reference WBCL001122
---	---	---

AIR GRILLES AND ACCESSORIES

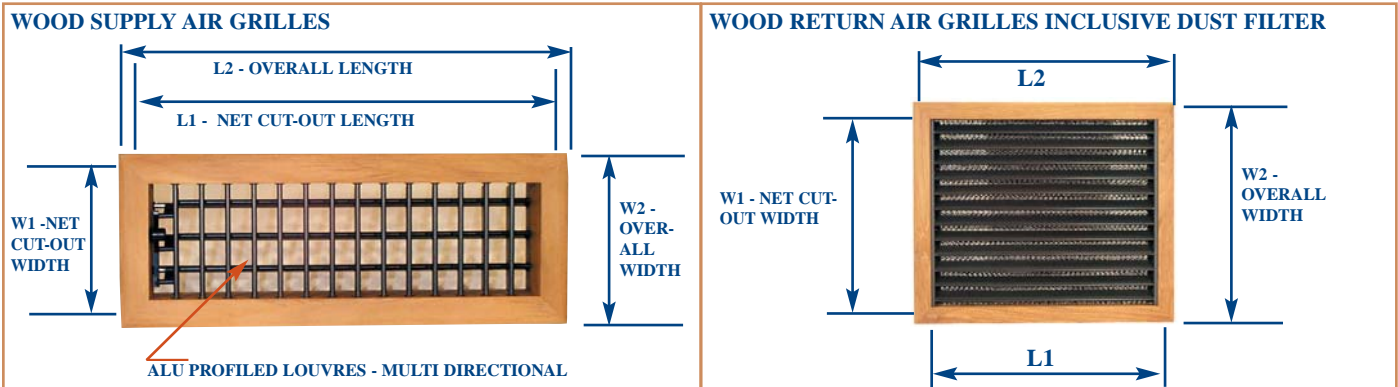

MODEL / DESCRIPTION	L1	L2	W1	W2	WB Ref.
8x4 TS (Teak - Supply Air)	202	230	100	128	WBCL004000
10x4 TS	252	281	100	128	WBCL004001
12x4 TS	304	332	100	128	WBCL004002
10x5 TS	252	281	125	152	WBCL004018
12x5 TS	304	332	125	152	WBCL004004
12x6 TS	304	332	152	179	WBCL004024
10x5 WGT (30° Wedge Type Supply)		280		150	WBCL004023
8x4 TSC (Teak Supply - Closeable)	202	230	100	128	WBCL004005
10x4 TSC	252	281	100	128	WBCL004019
12x4 TSC	304	332	100	128	WBCL004006
10x5 TSC	252	281	125	152	WBCL004022
12x5 TSC	304	332	125	152	WBCL004025
12x5 TR (Teak Return Air)	304	332	125	152	WBCL004020
11x8 TR	280	306	204	230	WBCL004017
14x7 TR	177	205	355	381	WBCL004007
12x10 TR	304	332	254	281	WBCL004021
14x10 TR	354	382	254	281	WBCL004008
14x12 TR	354	382	304	332	WBCL004009



NB : All teak grilles can be obtained on special request in the following woods : White Oak, Red Oak, Ash, Cherry, Mahogany and Poplar (for painting) - Only Teak and some Mahogany models are stocked - other woods are special deliveries.

PLASTIC SUPPLY AIR GRILLES - WHITE ABS

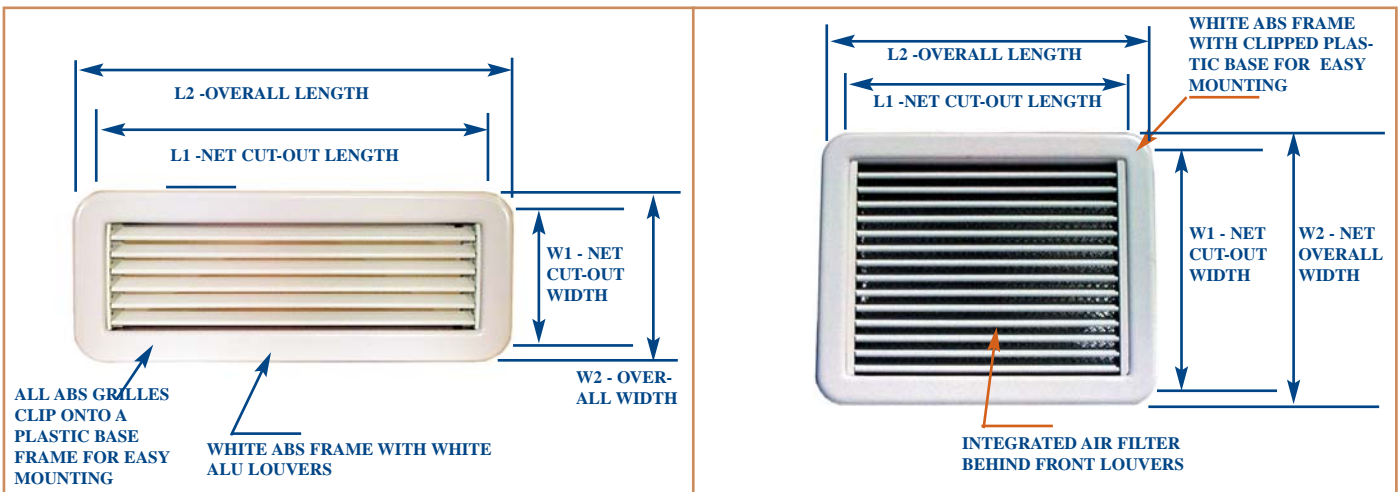

MODEL / DESCRIPTION	L1	L2	W1	W2	WB REFERENCE
10x4 PS (ABS Supply Air)	242	280	92	128	WBCL004030
12x4 PS	292	332	92	128	WBCL004031
10x5 PS	242	280	115	152	WBCL004032
10x6 PS	242	280	138	174	WBCL004033
10x8 PR (ABS Return Air)	242	281	190	232	WBCL004076
10x10 PR	242	281	242	281	WBCL004077
12x12 PR	292	332	292	332	WBCL004078
14x10 PR	342	382	242	281	WBCL004080
14x12 PR	342	382	292	332	WBCL004081
Black round Plastic adjustable grille	Overall diameter : 130 mm - Net cut-out : 105				WBCL004090
Brown round Plastic adjustable grille	Overall diameter : 130 mm - Net cut-out : 105				WBCL004091
White Round Plastic adjustable grille	Overall diameter : 130 mm - Net cut-out : 105				WBCL004092

HOW TO COMPOSE A COMPLETE DUCTING SYSTEM WITH MINIMAL FRICTION LOSSES

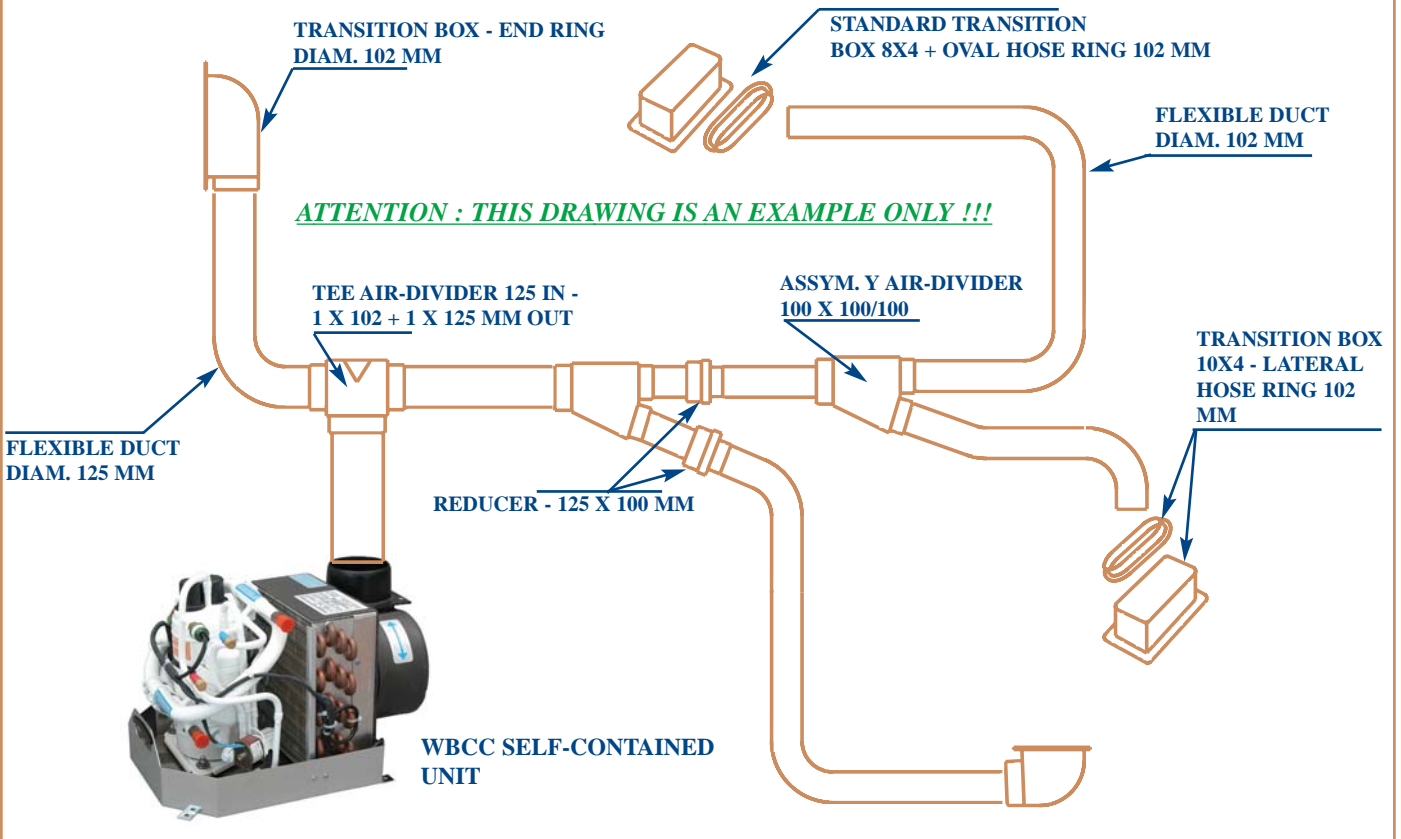

AIR DUCT SYSTEM COMPONENTS AND ACCESSORIES



DESCR.	MODEL	WB REF.	L x H	W /W1 / W2	D /D1 /D2 /D3
Female <T> Air-Divider	100/100F/100	WBCL001549	220 x 185 mm		100/100F/100
	100/125F/100	WBCL001560	220 x 185 mm		125/100F/100
	125/125F/100	WBCL001550	220 x 185 mm		125/125F/100
	125/125F/125	WBCL001555	220 x 185 mm		125/125F/125
Male <T> Air-Divider	100/100M/100	WBCL001551	220 x 185 mm		100/100M/100
	100/125M/100	WBCL001552	220 x 185 mm		100/125M/100
Standard Transition Box	8 x 4"	WBCL001501	252 x 130 mm	150 mm	
	10 x 4"	WBCL001502	304 x 130 mm	150 mm	
	12 x 4"	WBCL001503	352 x 130 mm	150 mm	
	12 x 5"	WBCL001505	352 x 130 mm	180 mm	
	10 x 5"	WBCL001506	304 x 130 mm	180 mm	
	12 x 6"	WBCL001507	352 x 130 mm	200 mm	
	10 x 6"	WBCL001508	304 x 130 mm	200 mm	
	Round Hose Adapters	HR4 - 100 mm	WBCL002502		134 mm
HR5 - 125 mm		WBCL002503		150 mm	125 mm
HR6 - 150 mm		WBCL002504		170 mm	150 mm
HR7 - 178 mm		WBCL002509		200 mm	175 mm
Oval Hose Rings	HO4 - 100 mm	WBCL002505	170 mm	100/55 mm	120 mm
	HO5 - 125 mm	WBCL002506	195 mm	110/65 mm	150 mm
	HO6 - 150 mm	WBCL002507	228 mm	120/72 mm	180 mm
	HO7 - 175 mm	WBCL002508	255 mm	140/84 mm	200 mm
Oblong Hose RingCools	HRE - 100 mm	WBCL002499			100 mm
	HRE - 125 mm	WBCL002500			125 mm
	HRE - 150 mm	WBCL002501			150 mm

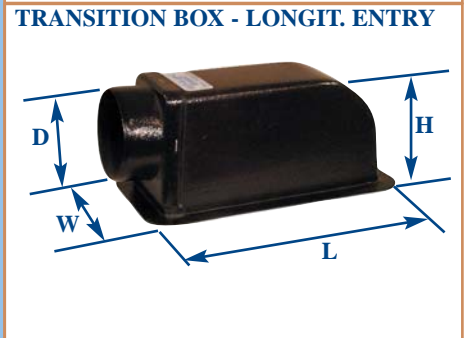
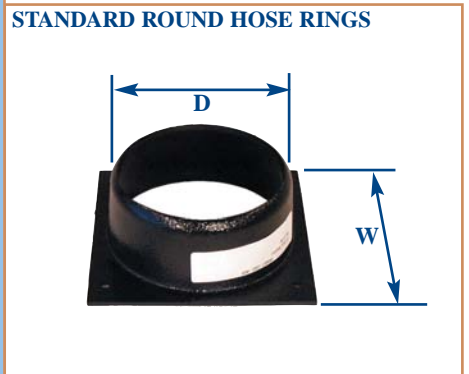

DESCR.	MODEL	WB Refer.	L x H	W/W1/W2	D/D1/D2
Transitions	8x4LN/100	WBCL001520	250 x 130 mm	150 mm	100 mm
End Rnd Entry	10x4LN/100	WBCL001521	305 x 130 mm	150 mm	100 mm
	12x4LN/100	WBCL001522	360 x 130 mm	150 mm	100 mm
	10x5LN/125	WBCL001523	304 x 130 mm	180 mm	125 mm
	12x5LN/125	WBCL001524	360 x 130 mm	180 mm	125 mm
Transitions Lat Oval Entry	8x4LT/OV100	WBCL001510	255 x 130 mm	155 mm	100 mm
	10x4LT/OV100	WBCL001530	305 x 130 mm	155 mm	100 mm
	10x4LT/OV125	WBCL001529	305 x 130 mm	155 mm	125 mm
	12x4LT/OV125	WBCL001528	360 x 130 mm	155 mm	125 mm
Transit. Back Oval Entry	8x4AR/OV100	WBCL001524	250 x 180 mm	155 mm	100 mm
	10x4AR/OV100	WBCL001525	305 x 180 mm	155 mm	100 mm
	10x4AR/OV125	WBCL001531	305 x 180 mm	155 mm	125 mm
	10x5AR/OV125	WBCL001526	305 x 180 mm	180 mm	125 mm
<Y> Assym. Transition	YAS100	WBCL001562	320 x 255 mm		100/100/100
	YAS125	WBCL001563	360 x 300 mm		125/125/125
	YAS125/100	WBCL001561	380 x 255 mm		125/100/100
	YAS125/125/100	WBCL001564	380 x 300 mm		125/125/100
Standard Flexible Air-Ducts	Cflex 102 mm	WBCL001804	10 ml		102 mm
	Cflex 127 mm	WBCL001805	10 ml		127 mm
	Cflex 150 mm	WBCL001806	10 ml		150 mm
Insulated Air-Ducts	CflexIso 102	WBCL001807	10 ml		102 mm
	CflexIso 127	WBCL001808	10 ml		127 mm
	CflexIso 152	WBCL001809	10 ml		152 mm
Add-on Tubular Insul.	Isosleeve 102	WBCL001810	10 ml		102 mm
Tubular Insul.	Isosleeve 127	WBCL001811	10 ml		127 mm
Tubular Insul.	Isosleeve 152	WBCL001812	10 ml		152 mm
Tubular Insul.	Isosleeve 180	WBCL001813	10 ml		180 mm
Oval Duct (1)	100x40 mm	WBCL007100	3 ml		
Oval Duct (1)	200x60 mm	WBCL007106	3 ml		
Elbow (2)	100x40 mm	WBCL007105			
Elbow (2)	200x60 mm	WBCL007108			
Elbow (3)	100x40 mm	WBCL007104			
Elbow (3)	200x60 mm	WBCL007111			
Oval/Round(4)	100x40/100	WBCL007102			
Oval/Round(4)	100x40/80	WBCL007117			
Oval/Round(4)	200x60/125	WBCL007109			
Oval/Round(5)	100x40/100	WBCL007103			
Oval/Round(5)	200x60/125	WBCL007110			
Oval Junct.(6)	100x40 mm	WBCL007101			
Oval Junct.(6)	200x60 mm	WBCL007107			
Reduction (7)	200 to 100	WBCL007112			
Oval Tee (8)	200 x 60	WBCL007114			
Oval/Round (9)	200x60/125	WBCL007115			
Tee Oval/R (10)	200x60/125	WBCL007116			

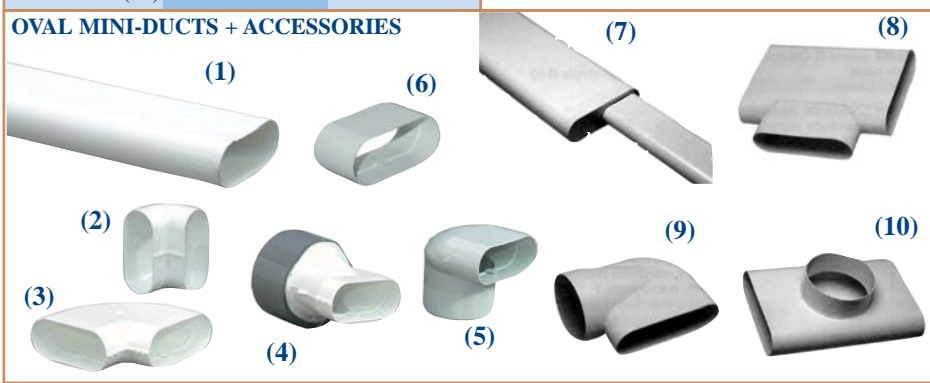
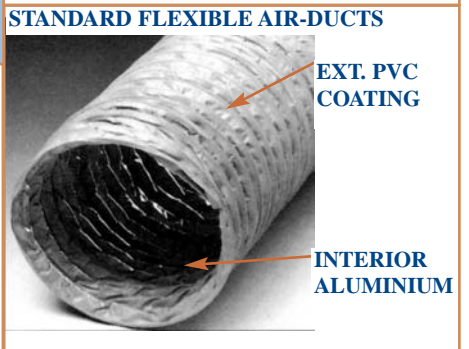
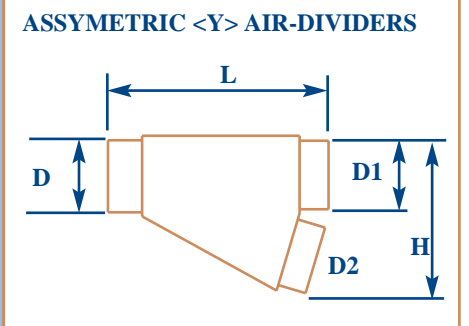
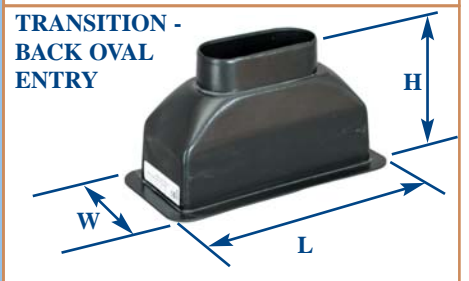

CENTRIFUGAL / CROSS-FLOW BLOWERS	STANDARD MODELS	WB Ref. 230V	WB Ref. 115V
		Centrifugal 2GRE15 120x62R - 275 m3/Hr	WBCL007020
Centrifugal 2GRE25 140x59R - 430 m3/Hr	WBCL007021	CLWB007031	
Centrifugal 2GRE35 140x59R - 500 m3/Hr	WBCL007022	CLWB007032	
Centrifugal 2GRE45 160x62R - 550 m3/Hr	WBCL007025		
Centrifugal 2GRE35 180x75R - 625 m3/Hr	WBCL007023	CLWB007033	
Centrifugal 2GFR65 180x70R - 900 m3/Hr	WBCL007024		
Cross-flow Blower 4000 BTU- 150 m3/hr	WBCL007016	CLWB007010	
Cross-flow Blower 6000 BTU- 190 m3/hr	WBCL007017	CLWB007011	
Cr.-flow Bl. 9000/12000 BTU- 250 m3/hr	WBCL007018	CLWB007012	
Cross-flow Blower 24000 BTU - 325 m3/hr	WBCL007019		

CHILLED WATER CIRCUIT PIPING AND ACCESSORIES

<p>EXPANSION TANKS / AUTO-AIRBLEEDERS</p>  <p>Diagram showing dimensions H and L for the expansion tank (2). Components (1) and (4) are also shown.</p>	<p>STANDARD EXPANSION TANKS Model 2.5l (1) Model 8 Litres (2) *) *) Available from 1st January 2005 H = 410 mm L = 250 mm D = 95 mm (Depth)</p> <p>AUTOMATIC AIR-BLEEDER (4) for chiller circuits (5/8") - to be mounted vertically on suction side of chiller circulation pump.</p>	<p>WB Reference WBCL002030 WBCL002031</p> <p>WBCL002035</p>
<p>TA HYDRONICS FLOW REGULATORS</p> 	<p>STANDARD MODELS Model STAD-15 - Diam. 15 mm (5/8") Model STAD-20 - Diam. 20 mm (3/4") Model STAD-25 - Diam. 25 mm (1") Model STAD-32 - Diam. 32 mm (1.25") Model STAD-40 - Diam. 40 mm (1.5") Model STAD-50 - Diam. 50 mm (2")</p>	<p>WB Reference WBCL002100 WBCL002101 WBCL002102 WBCL002103 WBCL002104 WBCL002105</p>
<p>DANFOSS 3-WAY VALVES</p>  <p>Diagram showing components (1) and (2).</p>	<p>STANDARD MODELS 3 way valve - 15mm (5/8") excl. fitting (1) 3 way valve - 20mm (3/4") excl. fitting (1) 3 way valve - 15mm (5/8") incl. fitting (2) 3 way valve - 20mm (3/4") incl. fitting (2)</p>	<p>WB Reference WBCL000770 WBCL000771 WBCL000772 WBCL000773</p>
<p>CHILLED WATER HOSES + ACCESSORIES</p>  <p>Diagram showing components (1) through (5).</p>	<p>STANDARD COMPONENTS Flexible Hose D12 + Insulation M3 - per ml (1) Flexible Hose D15 + Insulation M3 - per ml (1) Flexible Hose D20 + Insulation M3 - per ml (1) Flexible Hose D12 without Insulation - per ml (2) Flexible Hose D15 without Insulation - per ml (2) Flexible Hose D20 without Insulation - per ml (2) Tubular Insulation for D12 - per ml (4) Tubular Insulation for D15 - per ml (4) Tubular Insulation for D20 - per ml (4) Adhesive Foam 50mm wide - 15ml Roll (5) TEE 19-19-19 for D20 Hose (3) TEE 19-15-19 for reduction D20-D15 (3) TEE 19-12-19 for reduction D20-D12 (3) TEE 15-12-15 for reduction D15-D12 (3)</p>	<p>WB Reference WBCL002001 WBCL002002 WBCL002003 WBCL002004 WBCL002005 WBCL002006 WBCL002007 WBCL002008 WBCL002009 WBCL002010 WBCL002011 WBCL002012 WBCL002013 WBCL002014</p>
<p>CHILLED WATER CIRCUIT AC CALORIFIERS (Immersion Heaters)</p> 	<p>DESCRIPTION (Dimensions in mm) MODEL 10 KW 3PH 400V - L=675 ; H=200 - Wght 8 Kgs MODEL 15 KW 3PH 400V - L=1015; H=200 - Wght 11 Kgs MODEL 20 KW 3PH 400V - L=1015; H=200 - Wght 12 Kgs MODEL 30 KW 3PH 400V - L=1590; H=200 - Wght 19 Kgs MODEL 40 KW 3PH 400V - L=2130; H=200 - Wght 22 Kgs</p>  <p>Technical drawing showing dimensions: L, H, 70, 14, 32, 80, Ø 2" Gaz (F), Ø 1 1/2" Gaz (F), 180.</p>	<p>WB Reference WBCL002120 WBCL002121 WBCL002122 WBCL002123 WBCL002124</p>

Webasto - AIR-CONDITIONING

CO-AXIAL CUPRO-NICKEL SEA-WATER CONDENSERS

CUPRO-NICKEL INSIDE (Sea-water tube) - COPPER OUTSIDE (Refrigerant)

MODELS TYPE ES - OVAL - STACKED TUBES

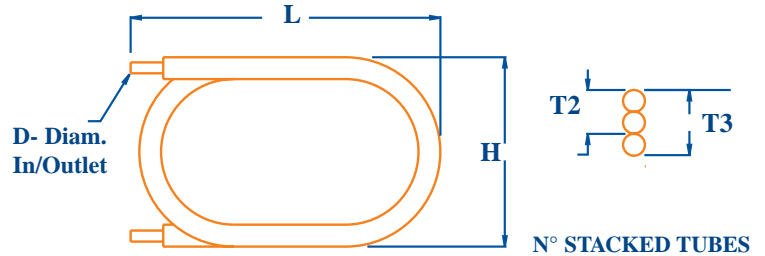

MODEL	L	H	T	D	Capacity/BTU	Refrig. unit	Air-condit. unit	WB Refer.
ES 06	260	214	T2=50	15	6000/9000	MF250/325/450	WBCC5/7/9	WBCL000660
ES 10	360	214	T2=50	15	12000	MF650/850/1100	WBCC12/WBCP12	WBCL000661
ES 16	360	238	T2=60	15	16000/20000	MF650/850/1100	WBCC/WBCP16/20	WBCL000662
ES 24	360	238	T3=90	15	24000		WBCC24/WBCP24	WBCL000663

MODELS TYPE S - SPIRAL - CLUSTERED TUBES

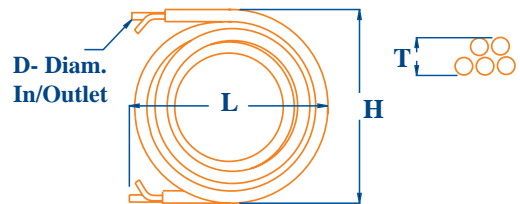

MODEL	L	H	T	D	Capacity/BTU	Refrig. unit	Airco units	WB Refer.
S-2-I	330	330	60	16	24000	MF2500	WBCP24	WBCL000652
S-3-I	340	355	65	19	36000	MF4000	WBCP30/36/WBCC30	WBCL000653
S-3.5-I	380	380	65	19	50000	N/A	WBCP42/48	WBCL000654
S-4-I	415	440	70	22	60000	N/A	WBCP180/240	WBCL000655
S-5-I	450	470	75	22	76000	N/A	WBCP72/84/216/288	WBCL000659
S-6-I	350	365	120	22	84000	N/A	WBCP252/336	WBCL000665
S-8-I	460	470	120	28	124000	N/A	WBCP488/504	WBCL000666
S-10-I	470	475	135	28	143000	N/A	WBCP572	WBCL000667

