

Installation / Troubleshooting Manual

Marine Cruisemaster Bosch, Diesel, K Series, U.S & Metric

This manual (part # 4001-406-05) applies to the following product part numbers:

- 1) 63080-BOS2K
- 2) 65040-2012K
- 3) 65040-2312K
- 4) 65040-BOS2K
- 5) 6505-201-2K
- 6) 6505-BOS-2K
- 7) 65080-2312K
- 8) 65080-BOS2K
- 9) 6510-201-2K
- 10) 6510-231-2K
- 11) 6510-BOS-2K
- 12) 65160-2312K
- 13) 65160-BOS2K
- 14) 6520-231-2K
- 15) 6520-BOS-2K
- 16) 6532-231-2K
- 17) 6532-BOS-2K
- 18) 6710-BOS-2K
- 19) 6720-BOS-2K

Flow Homogenizer Can Replacement

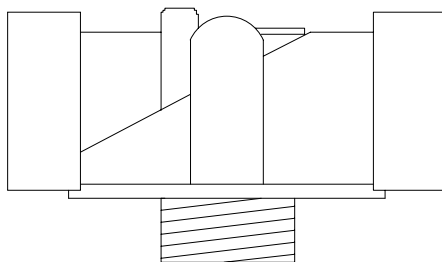

Aluminum Base

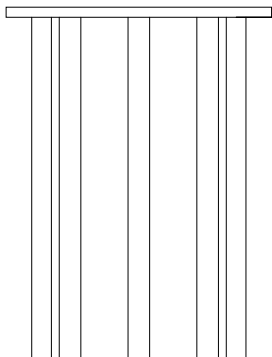

**Tube Assembly
P/N 4001-250-00**



Rubber Sealing Washer

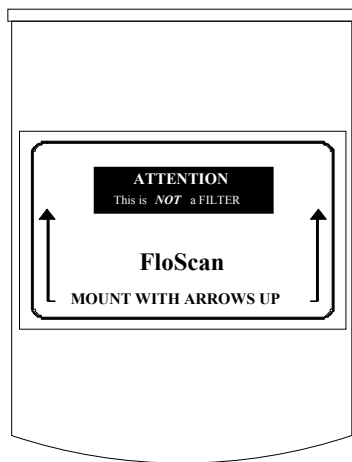

**Flow Homogenizer Can
P/N 4001-199-03**

1. Remove the old Flow Homogenizer can. A Claw type oil filter wrench, or pipe wrench may be needed.
 2. Remove the Brass Tube Subassembly and, Debris Screen, (If used) from the old can. Install them in new can.
 3. Put a coating of grease on the new Flow Homogenizer's rubber sealing washer.
 4. Clean the Aluminum base and put a coating of grease on the seal's mating surface.
 5. Place new Flow Homogenizer can on its Aluminum base. Turn until "Finger tight".
 6. Using a band type oil filter wrench, carefully rotate the can until tight, approximately $\frac{3}{4}$ of a turn past finger tight.
- Position a strip of rubber, (Bicycle tube or rubber glove) between the wrench and can. The rubber both increases friction and protects the can. Use caution as over-tightening will buckle or collapse the can.

Lo-Flo Pulsation Damper Can Replacement

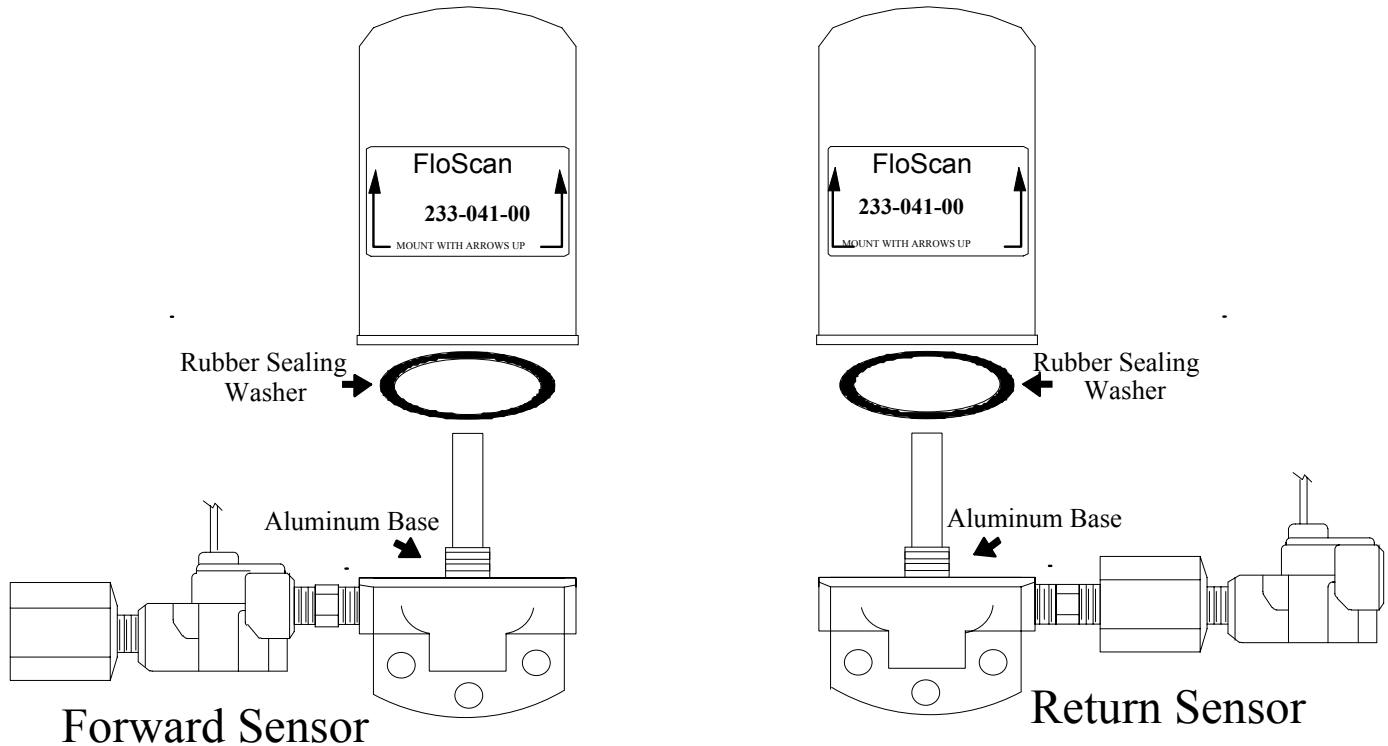

1. Remove the old Pulsation Damper can. A Claw type oil filter wrench, or pipe wrench may be needed.
 2. Put a coating of grease on both sides of the new Pulsation Dampers' rubber sealing washer.
 3. Clean the Aluminum base and put a coating of grease on the seal's mating surface.
 4. Place the new Pulsation Damper can on its Aluminum base. Turn until "Finger tight".
 5. Using a band type oil filter wrench, carefully rotate the can until tight, approximately $\frac{3}{4}$ of a turn past finger tight.
- Position a strip of rubber, (Bicycle tube or rubber glove) between the wrench and can. Rubber increases friction and protects the can. Use caution as over-tightening will buckle or collapse the can.

White Replacement K-Series Pulsation Damper Can P/N 233-041-00.

Hi-Cap Pulsation Damper Can Replacement

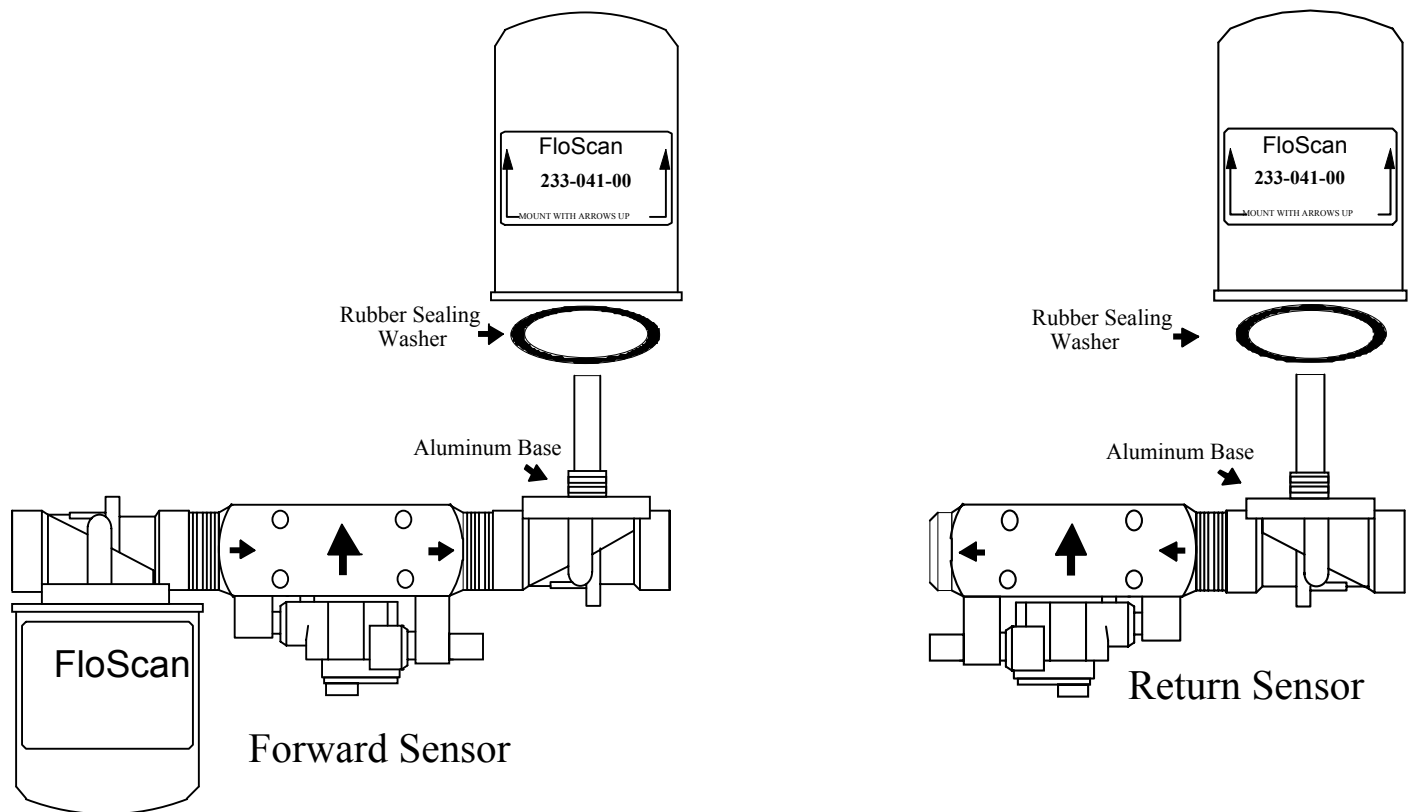

1. Remove the old Pulsation Damper can. A Claw type oil filter wrench, or pipe wrench may be needed.
 2. Put a coating of grease on both sides of the new Pulsation Dampers' rubber sealing washer.
 3. Clean the Aluminum base and put a coating of grease on the seal's mating surface.
 4. Place the new Pulsation Damper can on its Aluminum base. Turn until "Finger tight".
 5. Using a band type oil filter wrench, carefully rotate the can until tight, approximately $\frac{3}{4}$ of a turn past finger tight.
- Position a strip of rubber, (Bicycle tube or rubber glove) between the wrench and can. Rubber increases friction and protects the can. Use caution as over-tightening will buckle or collapse the can.

White Replacement K-Series Pulsation Damper Can P/N 233-041-00.



INSTALLATION PLANNING



READ ME FIRST - Detailed Mechanical & Electrical Planning Saves Installation Hours!

FloScan K Series systems are not difficult to install. Installation requires only basic electrical & mechanical skills. With forethought and planning, your system will be installed with few problems. Todd Walker, Yacht Electric Co., (954) 325-9091 regularly installs FloScan K Series Twin Diesel Systems in about 10 hours. Difficult installations may take several hours longer.

I. Installation Preparation:

Review the pre-installation booklet, mechanical installation instructions, and survey your vessel. Determine where the Sensor(s), Sensor Assemblies, Switches and Instruments are to be mounted. Place them at their approximate locations. Determine fitting size and types required for each plumbing connection, (JIC, SAE, NPT, NPTF, or Hose Barb).

FloScan K-Series Hi-Cap Diesel Forward Sensor Assemblies have 1" Female NPT ports.

FloScan K-Series Hi-Cap Diesel Return Sensor Assemblies have 1" inlet and 1/2" outlet Female NPT ports.

FloScan Hi-Flo, (-10) Diesel and Gasoline Sensors have 1/2" Female NPT ports.

FloScan K-Series Lo-Flo Diesel and Gasoline System Components, (Sensors and Pulsation Dampers) have 1/4" Female NPT ports.

Review the electrical installation instructions. Open and survey your vessels wire ways. Determine if it would be easier to run a 3-conductor cable from each sensor to the instrument, or install a junction box, (J-Box) with terminal strip in the engine room. The J-Box requires a 4-conductor cable from it to the instrument, and a 3-conductor cable from each sensor. Measure cable lengths from sensor(s) to J-Box, (If used) to Instrument. Tachometers require a separate 2-conductor cable. If there's an existing tachometer, its signal wires can be used.

II. Mechanical Installation:

Install or mount the Sensor(s) or Sensor Assemblies, Instruments and Switches, (Reset, MPG).

III. Plumbing:

Most K Series and -10 installations do not require additional fuel hose. Mount the sensor(s) or sensor assemblies where they're to be installed. On installations using **Fabric Braid A-1 Fuel Hose** install the correct HB X MNPT fitting into each sensor or sensor assembly. Always assemble fittings using a fuel proof pipe thread sealant. **Never use Teflon Tape**. Use a hose cutter or knife to cut the fuel hose. Next install the hose onto the barb fittings. Hose should not be twisted, have adequate slack, an ample radius at all bends and be supported at reasonable distances, approximately 2-4 feet. When clamping hose onto the barbs, use 2 narrow or 1 wide stainless hose clamp on each hose end.

Wire Braid A-1 Aeroquip Type Fuel Hose or Hydraulic Hose: Mount the sensor(s) or sensor assemblies where they're to be installed. Mark the hose where it is to be cut. Remove hose and bring it to a hydraulic shop. Have them cut the hose and install hose ends. Reinstall the hoses and install the correct fitting into each sensor or sensor assembly. Always assemble fittings using a fuel proof pipe thread sealant. **Never use Teflon Tape**. Hoses should not be twisted, have adequate slack, an ample radius at all bends and be adequately supported at reasonable distances, approximately 2-4 feet. AP-50 copper sealing washers, (Connie Seals) or Flaretite seals may be required to seal JIC & SAE fittings.

IV. Electrical Installation:

Run cables between Sensor(s), J-Box, (If used) and Instrument(s). Cables must be adequately supported at reasonable distances, approximately 2-4 feet.

Wire Terminations—Referring to the wiring diagram. Connect Sensor, Instrument and Switches to their respective wires with crimp type butt or ring connectors. Always cover connectors and wire ends with heat shrink tubing.

V. Pre-Startup:

Prime the fuel system. If you have an electric priming or boost pump, circulate fuel for 10 minutes while checking for leaks. If not, use the engines manual pump. Before starting, open the lift pumps' outlet fitting slightly. Before start-up, verify that all fuel system fittings are tight.

VI. System Start-Up:

Start and run your engines. Look for leaks and other installation problems. If system is not operating properly refer to the Troubleshooting Instructions and correct any deficiencies.

VII. Calibration:

When system is running properly, refer to the calibration instructions and calibrate your system. If installed properly, initial calibration takes less than 1 hour. After consuming some fuel, final calibration should only take a few minutes.

USCG approved fuel hose with either fabric or wire reinforcing braid meet the following standards:

<u>Hose Marking</u>	<u>Permeation Rating</u>	<u>2½ Minute Fire Test</u>
USCG Type A-1	100g/m²/24hrs.	Required
USCG Type A-2	300g/m²/24hrs.	Required
USCG Type B-1	100g/m²/24hrs.	Not Required
USCG Type B-2	300g/m²/24hrs.	Not Required

Table I

Installation Do's & Don'ts

Do	Don't
Use a Fuel Proof Pipe Thread Sealant when assembling fittings into fuel system components, (Loctite PST, Leak-Lock, or equivalent).	<u>Never use Teflon Tape!</u>
Use thin wall, low pressure, full flow type NPT or NPTF hose barb fittings.	Don't use Push-Lok, or Barb-Tite fittings. Avoid using JIC or SAE swivel fittings. If used always install copper conical sealing washers, (Connie seals) or fitting seals on fittings.
Double clamp all hose barb fittings.	Avoid using 90° elbow fittings.
Install Sensor(s) at a low point in the fuel system, as far from the engine as practical. Fuel must travel, "Up-hill" slightly after leaving the sensor. Verify correct orientation and fuel flow direction.	If possible, avoid bolting or mounting sensor(s) directly onto the engine.
Install Forward Sensors on the Fuel Pumps' Inlet or Vacuum side, and not on the pressure side.	If on the Pressure Side, Limit Sensor System Operating Pressure to 20 PSI or Less.
Always use 30-micron primary filters.	Avoid 2 or 5 micron primary filters.
Wire with Shielded Cable. Use a dedicated shielded pair for Magnetic Pickup Tachometer Senders.	Never use unshielded wires on Magnetic Pickup Tachometer Senders.
Connect all, "Ground" wires to a Ground Buss, or directly to the Battery's Negative Terminal. Connect or, "Ground" wire shields to the engine block.	Never connect Instrument or Sensor "Ground" wires to the hull, engine block, or other machinery.
On Instruments with a GPS interface, connect FloScan's Data (+) to the GPS signal output. Connect Data (-) to the GPS signal ground.	Do not connect FloScan's Data (-) to the GPS Data (-).
Always use non-illuminated switches for Totalizer Reset, Port/Starboard Select, Hours/Synch, and GPH/MPG.	Never use illuminated, or back-lit switches.

MECHANICAL & WIRING OVERVIEW, (K Series & -10 Systems)

To Ensure System Accuracy, Follow All Installation Instructions.

- Sensor Placement.** Determine where the Flow Sensor, or Flow Sensor-Pulsation Damper assembly is to be installed. Install the sensor, or sensor-pulsation damper assembly so that the two fuel flow arrows, (→ →) or the, (IN and OUT) markings are on a horizontal plane. All orientation arrows, (↑) must be pointing up. The forward sensor or forward sensor-pulsation damper assembly must be installed downstream of the primary filter. Do not install the sensor or either sensor assembly at a high point in the fuel system. This could negatively impact system accuracy by trapping air. The fuel return line between the return sensors' outlet port and fuel tank should be at least 12" long and have a 1 to 2" upward rise. This keeps the return sensor flooded, improving accuracy. Place sensor assemblies in a protected location away from water spray.

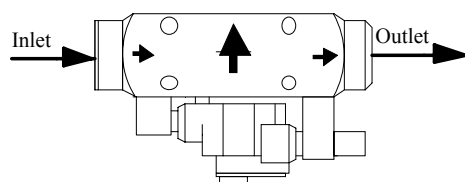
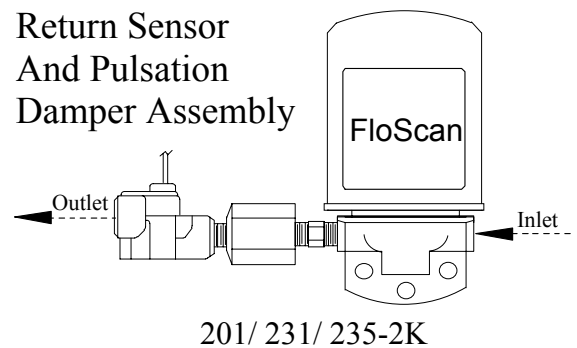
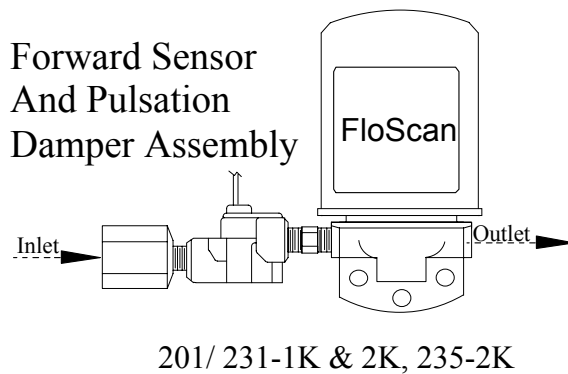
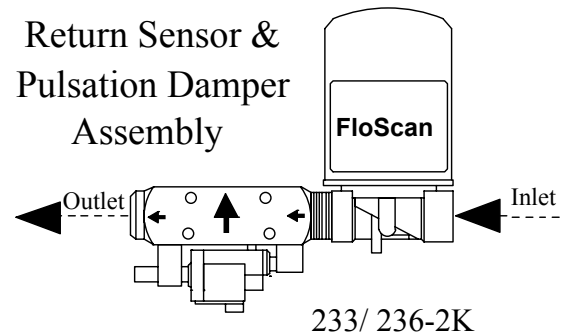
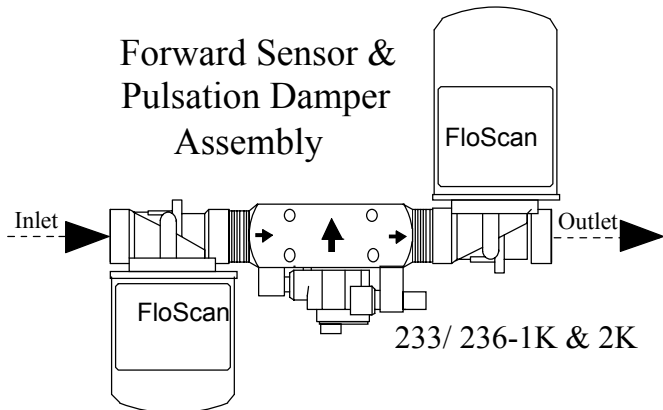

233C-10 & 233D-10 (Cummins PT Systems)

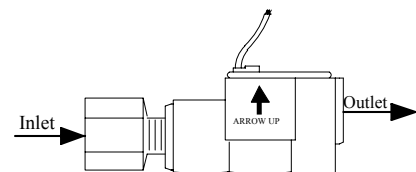

231-10 (Cummins PT Systems)

- **Determine fitting type & size.** Minimize the number of elbows and fittings. If swivel fittings are used, (JIC or SAE) their mating surfaces must be sealed with Copper Conical Sealing Washer, (Connie Seals) or fitting seals. Fitting seals may be purchased through Fittings Inc. in Seattle, WA (206) 767-4670, 1-800-552-0632, or a local hydraulic supply house.



- **Select Instrument Mounting Location.** The instruments' face is waterproof and a gasket is provided to seal its bezel to the control panel. Choose a location away from the compass. Install 65/6600 series instruments 12" away from compass. Choose a shaded location since direct sunlight may cause the LCD display to temporarily turn. This does not damage the LCD, but makes it impossible to read until cooling down. Make a cutout in the instrument panel for the instrument. The instruments' maximum depth is 3 1/2" minus the thickness of the console panel.

Instrument Series	Cutout Size
6500/6600	3 1/16"
7500/7600, 8500/8600, 9500/9600, TwinScan	3 3/8"

- **Wiring.** Determine wiring run length and the number of switches needed, (always use good quality marine grade switches). Use 18 AWG conductors on runs under 50'. 16 AWG for runs over 50'.
- **Run & Connect Wires.** Wire one system at a time. Always begin with the Black, "Ground" wires. Each Black sensor wire must be connected to the Black, "Instrument Ground" wire. Use a single wire to connect these Black wires to the battery's negative terminal, or to the ground buss. **For the system to operate properly the, "Ground" wires must be connected in this manner.** Connect other wires per the wiring diagram. Leave the RED, power wire for last.
- **Tachometer Installation Options.** 75/7600, 85/8600, and 95/9600 series tachometers require one or two additional wires. If your engine isn't equipped with a tachometer sender determine which type it requires, (AC Signal Generator or Magnetic Pickup) and install one. Some engine alternators produce a tachometer signal and can be used as the tachometer sender. Mechanically driven AC signal generators and magnetic pickups are available from FloScan and most marine dealers. Hewitt, Motorola, VDO and Stewart Warner are some of the more common brands.
 1. **Keep Existing Tachometer(s).** Connect the FloScan tachometers' Yellow and Violet signal wires to the existing tachometer. If the tachometer sender wire(s) are not marked, trace them from the tachometer sender up to the existing tachometer. If one sender lead is grounded, connect the FloScan tachometers Yellow signal wire to the ungrounded lead or terminal. Connect the VIOLET wire to a Ground Buss, or Battery Minus.

2. **Replace Existing Tachometer(s).** FloScan MFI instruments have a 3 3/8" outside diameter. This is a common size and fits into most instrument mounting holes. Identify the engines' tachometer sender wires. Connect the FloScan tachometers' Yellow and Violet signal wires to the sender wires. If one sender lead is grounded, connect the FloScan tachometers Yellow signal wire to the ungrounded lead or terminal. Connect the VIOLET wire to a Ground Buss, or Battery Minus.
3. **New Tachometer(s).** Run a dedicated shielded pair of wires between the instrument and tachometer sender, (This is especially important with Magnetic Pickup senders). Ground the shield only in the engine room.
 - **Magnetic Pickup & AC Signal Generator Tachometer Senders:** Connect the FloScan tachometers' Yellow signal wire to one sender terminal. Connect the Violet wire to the other terminal.
 - **Engine Alternators:** Connect the FloScan tachometers Yellow signal wire to the alternators' tachometer output terminal. This terminal is usually marked as **TACH**, or **SIG**. Connect the VIOLET wire to a Ground Buss, or Battery Minus.
- **Pre-Startup & Installation Check.** Prime the fuel system. If you have an electric priming or boost pump, circulate fuel for 10 minutes while checking for leaks. If not, use the engines manual pump. Before starting, "Crack" the lift pumps' outlet fitting slightly. Continue pumping until system is fully primed. Before start-up verify that all fuel system fittings are tight.
- **System Start-Up.** Start and run your engines. Survey the installation for leaks and other problems. If the system is not operating properly refer to the Troubleshooting Instructions and correct any deficiencies. When the engine reaches operating temperature increase engine speed to about 1500-2000 RPM. Letting it run for five or ten minute's helps purge residual air from the system.
- Any vacuum leaks between the fuel tank and lift pump will allow air to be drawn into the system. These leaks cause high and/or fluctuating GPH readings. Only severe leaks affect engine performance, but all leaks affect sensor performance and instrument readings. Vacuum or suction leaks occur at improperly sealed primary filters, loose packing nuts on cross over & shut off valves and improperly sealed fittings. Vacuum leaks can also occur from corroded copper fuel lines and chaffed fuel hose, (where it rubs against bulkheads or engine parts). To verify that a suction leak is present, temporarily insert a clear piece of fuel resistant tubing downstream of the Forward Sensors' outlet. Observe the clear hose for at least two minutes looking for bubbles. Bubbles can appear as a constant stream of small bubbles, or as an occasional larger bubble. Tighten all possible leak sources, grease primary filter seals and install fitting seals on JIC/SAE fittings. Continue to observe the clear tubing until it runs clear without any bubbles. Flex or wiggle rubber hose sections while observing the clear tubing. If bubble volume increases inspect the hose and check its fittings. Repair as necessary.
- When idling in neutral, (No Load) GPH fluctuations can also be caused by the governor trying to maintain a steady engine RPM.
- **Calibration.** When the system is running properly, refer to the calibration instructions and calibrate your system. If installed properly, initial calibration takes much less than 1 hour. After consuming some fuel, final calibration should only take a few minutes.

Fuel Flow Schematic - Low Flow Diesel Systems (BOS, 201, 231 & 235-2K)

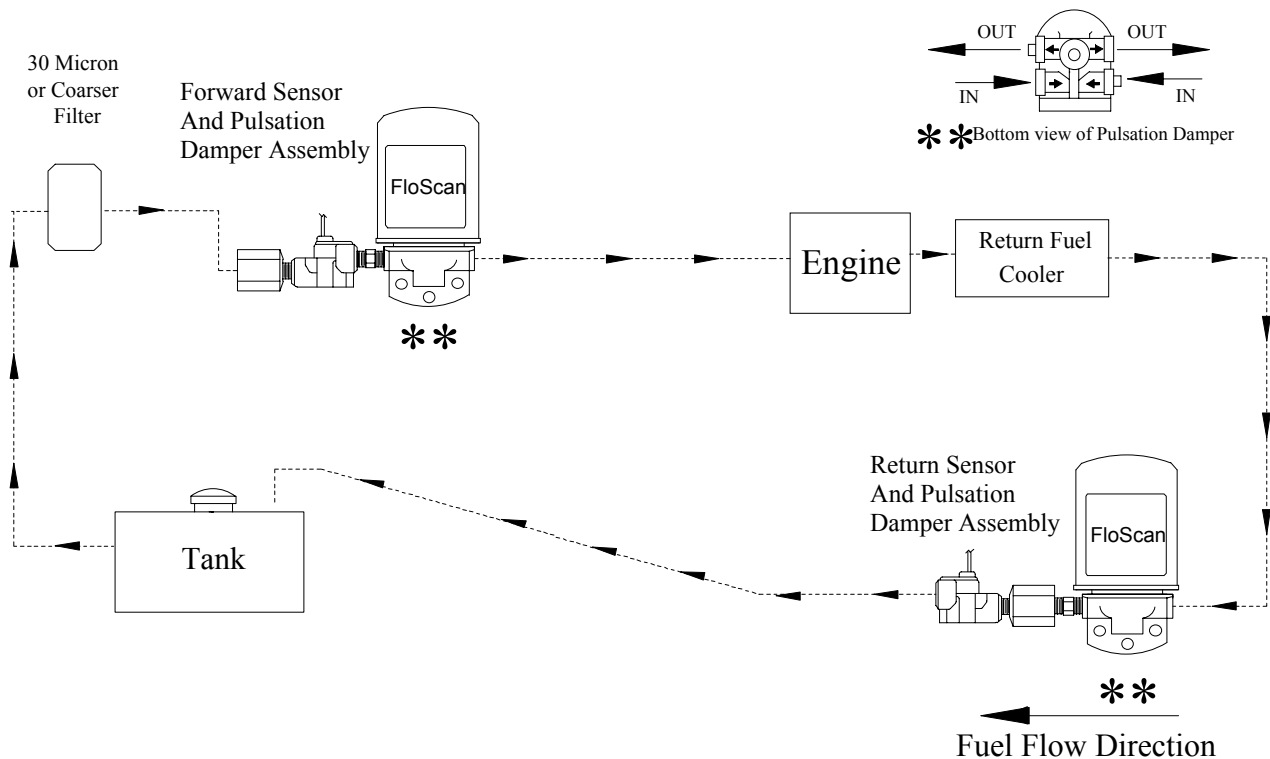

***Caution: Diesel System Components are not designed for use on Gasoline Fuel Systems.**

FloScan Sensor & Pulsation Damper Plumbing Guidelines:

1. Install flow sensor & pulsation damper assemblies with their orientation arrows pointing UP ↑. Fuel must enter through the port marked IN, or with an inward pointing arrow, (→←) and exit through the port marked OUT, or with an outward pointing arrow, (←→). Install the sensor – pulsation damper assembly as far from the engine as practical. Maximizing fuel line length between engine and sensor – pulsation damper assembly improves instrument accuracy. Pipe plugs are provided to block unused ports. Refer to Pulsation Damper ** Bottom View.
2. Maintaining high flow velocities through the fuel lines minimizes sensor oscillations. Use the smallest approved fuel line diameter for your engine, especially on the return line. Consult the engine owners' manual for more information. To insure that the return sensor remains flooded, install the return sensor – pulsation damper assembly at a low point in the system. Fuel should travel "Up-Hill" upon exiting the return sensor.
3. Flow sensors must always be installed downstream of a filter or debris screen (no finer than 30 micron). Particles larger than 1200 microns may jam the sensors' rotor and cause it to fail.

FloScan Low Flow 2K Diesel System Kits

Forward Flow Sensor	Return Flow Sensor	KIT TYPE
201	201	201-2K
231	201	BOS-2K
231	231	231-2K
*235	*235	*235-2K

4. Flow sensor model numbers are molded into the colored plastic wire cap. Sensors are shipped in matched pairs. They must not be mixed on twin engine installations. Match codes are identified by a single stand-alone letter stamped into the sensor body, or from a colored sticker.
5. Model *235 sensors are temperature compensated and stamped with their Instruments serial number, xxxxF (Forward), xxxxR (Return). *235-2K Temp-Comp sensor kits are precisely calibrated and matched to each instrument. Sensors are labeled FORWARD and RETURN and must be installed in these positions for proper operation. The instrument head serial number must match the flow sensor(s) serial number.
6. If there's a shut-off valve in the return line, do not operate the engine with it closed. Fuel system pressure could exceed the system working pressure of 40 PSI, and may cause a catastrophic system failure. You should either tag the valve so the engine will not run when it is closed for maintenance, or bypass it with a relief valve.

NOTE: Minimize the number of 90° elbows and pipe fittings. Excessive use may create a high vacuum, fuel restricting, pressure drop across the forward part of the fuel system. Refer to the engine owners' manual for maximum fuel pump inlet vacuum. A vacuum gauge can be used to confirm that the system is within limits.

CAUTION: DO NOT OVER TIGHTEN FITTINGS. Torque sensor and pulsation damper pipe thread fittings to a maximum of 15 ft.-lb. (180 inch-lb.), or 2 full turns past hand tight, whichever comes first. Leak Lock pipe thread sealant is provided with your system. Use it on all pipe thread fittings. **DO NOT USE TEFLON TAPE.**

Series 5500(0)/56100/5800(0)/6500(0) CruiseMaster, All Multi Function Instruments, & TwinScan®

SET UP

Wire & Switches: Use 18 AWG stranded wire on runs under 50'. For runs over 50' use 16 AWG, (Shielded wire is recommended for all Diesel systems, and suggested for Inboard & I/O gasoline systems. Always, "Ground" wire shield or shield drain wire in the engine room by connecting it to the bonding system, or engine block). The double wiring harness for twin engine Pulse/NMEA Diesel installations is included in all, (97/9800(0)) kits. FloScan suggests using J-Boxes, Terminal Blocks, and three conductor cables between the sensors and instrument to make wiring easier.

Install Single Pole Single Throw (SPST) switches for Totalizer Reset, Port-Starboard Select, Engine Hours / Synchronizer, and GPH / MPG, (switches are not included in kit). To determine which switch types are required for your system, refer to the table below. All instruments except TwinScan Tachometers require a totalizer reset switch.

SYSTEM	TOTALIZER RESET	PORT/STBD (Twin Systems)	HOURS/ SYNCH	GPH/ MPG	MPG/ SYNCH
2500	SPST or Momentary <u>ON</u>	SPST	NA	NA	NA
5500	SPST or Momentary <u>OFF</u>	SPST	NA	NA	NA
5800	SPST or Momentary <u>OFF</u>	NA	NA	NA	NA
6500/6600	SPST or Momentary <u>OFF</u>	SPST Twin Cummins (PT) only	NA	NA	NA
ALL 7XXX or 8XXX MFI	SPST or Momentary <u>ON</u>	SPST	SPST	NA	NA
All 9XXX MFI	SPST or Momentary <u>ON</u>	SPST	SPST	SPST	NA
TwinScan GPH	SPST or Momentary <u>ON</u>	NA	NA	NA	SPST w/ both
TwinScan Tach	NA	NA	NA	NA	GPH & Tach

NA = Not Applicable

Grounding: Each Black sensor wire must be connected directly to the Black, "Instrument Ground" wire. Use a single wire to connect the Black wire junction to the battery's negative terminal, or a ground buss.

Power: FloScan Instruments & sensors operate on 9 to 12 VDC. Voltages exceeding 16 VDC will damage the equipment. 24 & 32 VDC systems must be reduced to 12 VDC. Two different types of voltage reducers are available through FloScan.

CONNECT THE WIRES

Installation: Connect wires one at a time and Install heat shrink before proceeding to the next wire, (refer to wiring diagram). Connect ground wires first, (BLACK instrument ground wire to the BLACK sensor wires. Connect this junction to the battery's negative terminal or the ground buss). Connect all other wires leaving the Red power wires for last to prevent short circuits during the installation.

Splicing: Splice or join individual wires per the diagram. Slide heat shrink tubing over the splices to prevent shorts. Do not seal splices until the installation is finished and has been tested.

An adequate number of crimp-on connectors and heat-shrink tubing are included with system. The heat-shrink is a special type that will bond to wire insulation and make a watertight connection. See diagram for proper tubing application. Crimp-on connectors are sized for 18 or 20 gauge stranded wire.

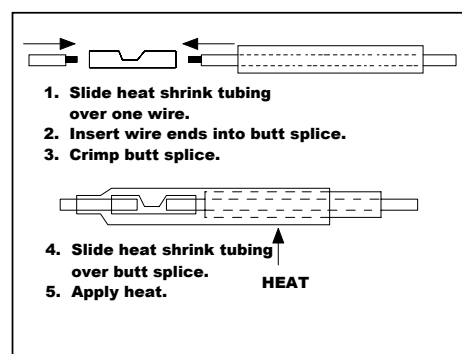

FINAL ACTIONS

Check Electrical Installation: Test all connections. Support and secure all dangling wires. Start engine and calibrate system.

Series 6500 / 6600, 65000 / 66000 GPH Cruisemaster

To ensure years of trouble free operation, please read these instructions carefully before beginning your installation

Your Cruisemaster is supplied with a sufficient number of crimp-on and heat-shrink tubing to make a typical installation. The heat-shrink tubing is a special type that will bond with the wire insulation to make a water tight connection. See the diagram to right for proper application of the tubing. The crimp-on connectors work best with 18 gauge stranded wire (wire not included).

Connect the wires one at a time (see wiring diagram for your particular installation) and install heat shrink before proceeding to the next wire, saving the *RED* wire to +12V until last to prevent short circuits during the installation.

NOTE: On installations with two flow sensors, the *WHITE* wire **MUST** go to the Forward Flow Sensor and the *BROWN* wire **MUST** go to the Return Flow Sensor. Reversing these wires will cause the instrument to show "O" flow. The *RED* wire (to +12V Supply) should be connected to the keyed side of the ignition switch. If power is not being supplied through a fuse panel, a 1 amp fuse should be installed at the source of power (+12VDC).

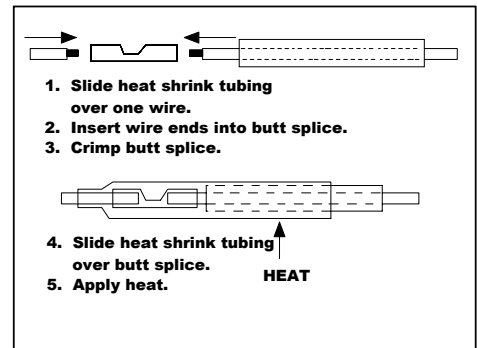

SYSTEM MUST BE PROPERLY GROUNDED FOR CORRECT OPERATION

Run a stranded ground wire from the negative terminal of the battery and splice it into the black wire common between the flow sensor(s) and the instrument head. The Cruisemaster internal circuitry is isolated from the can at the instrument head to prevent ground loop interference. Connect to ground only at the black wire junction to the flow sensor(s).

The *BLUE* wire is used for troubleshooting only. Leave disconnected for normal operation. For the Cruisemaster installation a single pole, single throw (SPST) switch is required (not supplied) to reset the totalizer. A good selection is a (SPST) momentary *OFF*. Connect the *GREEN* wire through the reset switch to a constant +12VDC. The display only uses 70 microamps (.0007 amps) of power, so it will not appreciably drain your batteries even for an extended period of time. If your boat is equipped with a *MASTER BATTERY SWITCH* and you do not want to lose the totalizer memory, you will need to run a power wire through a 1/4 amp fuse to the battery. The fuse is to protect the wiring and should be as close to the battery as possible.

Connect one *BLACK* wire from the illumination bulb to the illumination circuit and the other *BLACK* wire to instrument ground. It makes no difference which one gets power.

TO RESET THE TOTALIZER

Select the *OFF* position of the *Totalizer reset switch* for approximately 15 seconds. Once the totalizer has been reset to zero, select the *ON* position of the *Totalizer reset switch* for normal operation.

LOCATION OF INSTRUMENT

The series 6500 dial meter requires a 3 1/16" diameter cutout. The instrument contains a magnet which may affect your compass, so some care is required in choosing its mounting location.

WIRING DIAGRAM

Series 5800/58000 6500/65000 6600/66000 Gas/Diesel Cruisemaster GPH Instrument with LCD Totalizer

WIRING LEGEND

WIRE COLOR	FUNCTION
RED	Ignition +12VDC
GREEN	Totalizer Memory Constant +12VDC
BLACK	Instrument Ground
BLUE	Diagnostic
WHITE	Forward flow signal
BROWN	Not Connected (return sensor if utilized)

Diesel engines using only one sensor

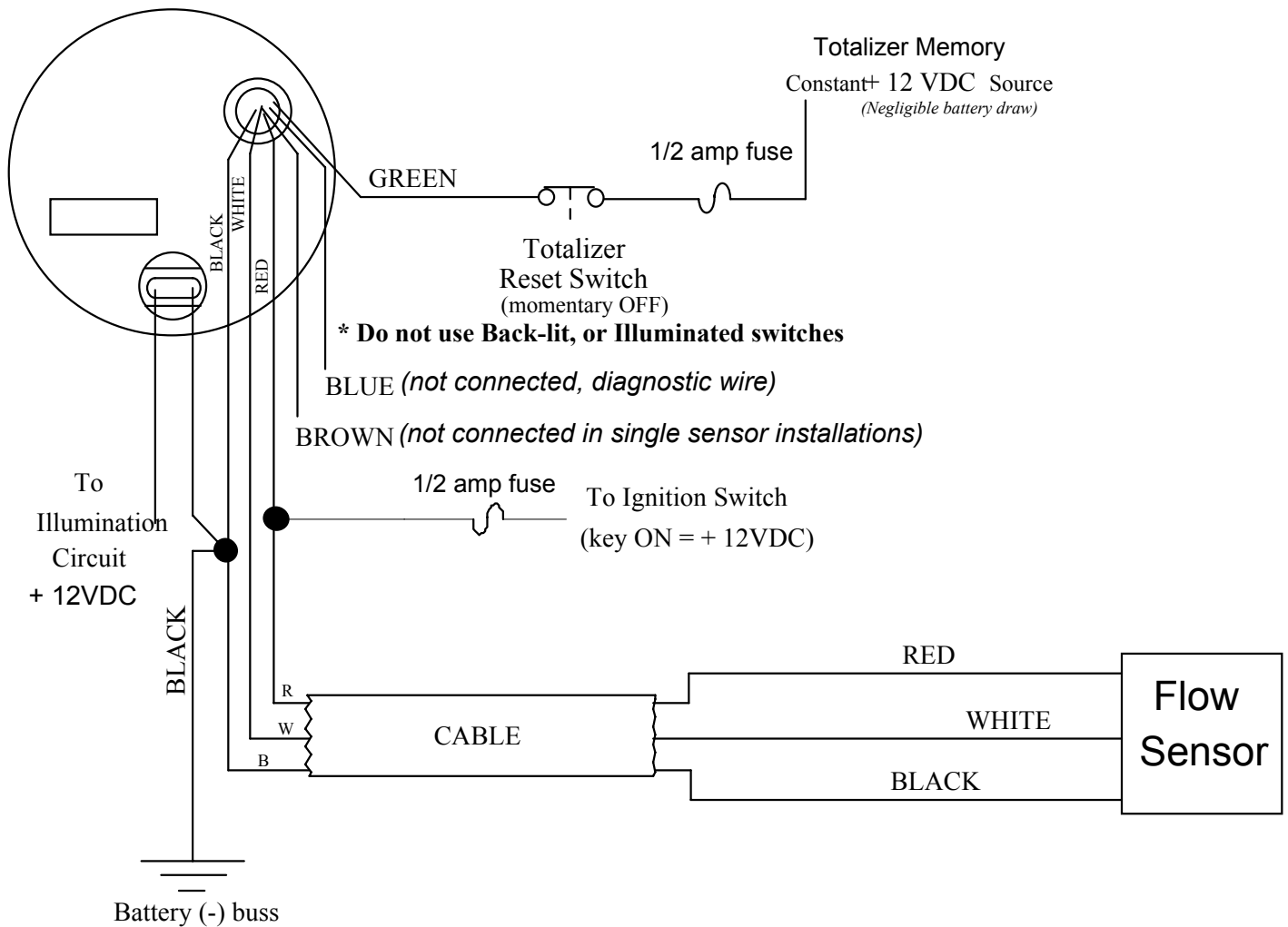

Forward and Return Sensor Gasoline EFI & Diesel Engine Installations

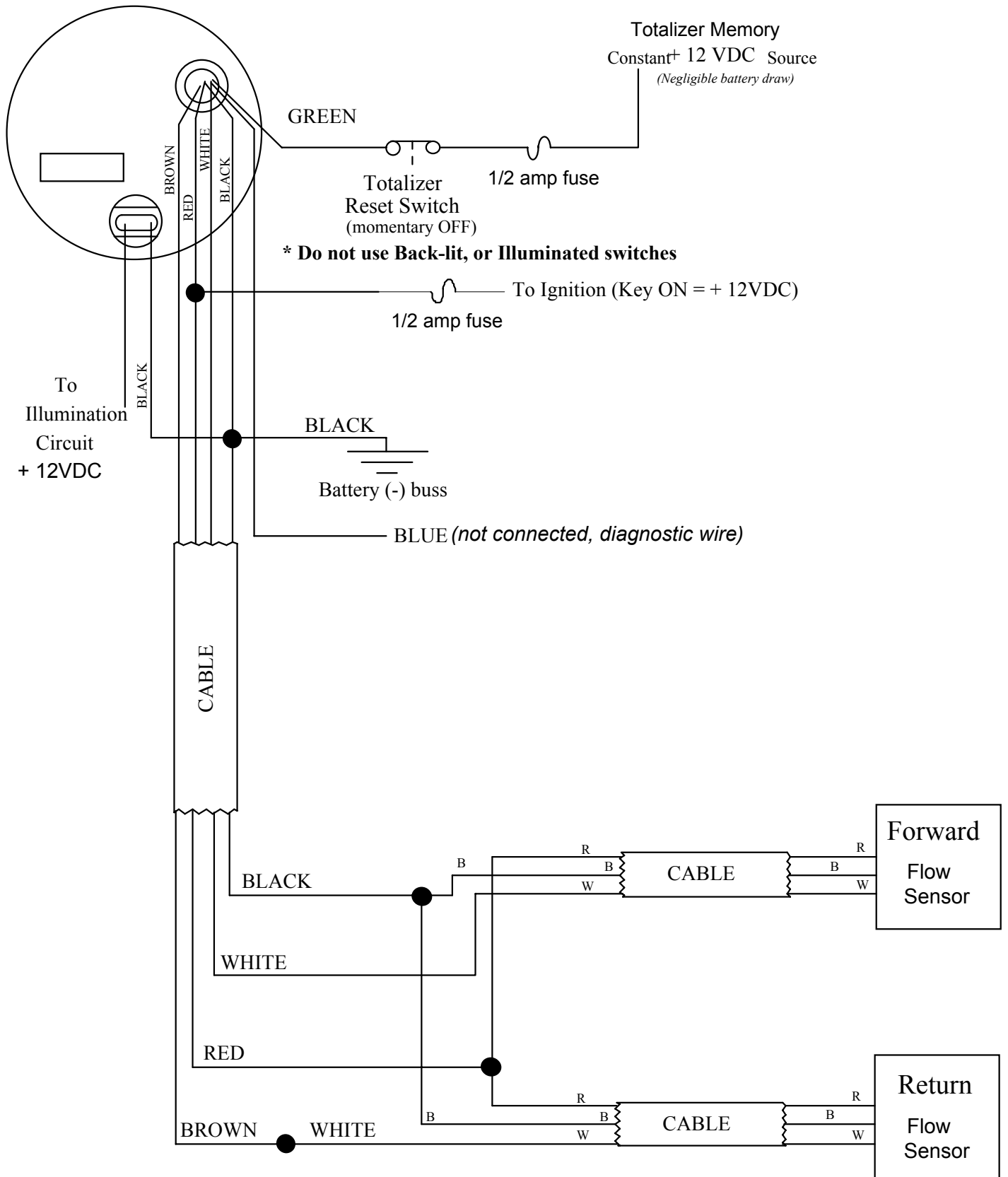

NOTE: For twin engine installations, you will repeat the wiring shown above for each engine.

Series 5800/58000, 6500/65000 Analog Instrument Return Flow Calibration

There are nine, "Dip" switches located on the back of your 6500 Series Instrument. These switches are used to calibrate the instrument prior to use. Switches 1 through 7 and 9 are shipped in the OFF position, switch 8 is ON. Before proceeding with the calibration, verify that switch 8 is ON, and that the rest are OFF.

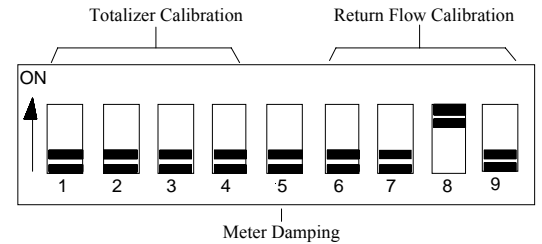

Instrument calibration is accomplished in two steps. First the Return Flow is calibrated. Then after operating the vessel and consuming one or two tanks of fuel the totalizer is adjusted.

Return Flow Calibration:

Referring to Tables 1 and 2, do the following to calibrate the return flow sensor.

1. Start your engine. Let it idle until it reaches its normal operating temperature.
2. Increase engine speed to 1800 RPM, (Unloaded) for 1 or 2 minutes. This purges any air trapped in the fuel lines.
3. Return the engine to low idle. Referring to *table 1*, determine its' no load fuel consumption.

Table 1	No Load Idle Consumption	
	HP	Non-Turbo
100-400	0.1-0.5 GPH, (1-2 LPH)	0.3-0.7 GPH, (2-3 LPH)
400-750	0.8 GPH, (3 LPH)	1.0 GPH, (3-4 LPH)
750-1000	1.0 GPH, (4 LPH)	1.5 GPH, (5-6 LPH)
1000-1250	2.0 GPH, (7-8 LPH)	2.5 GPH, (9-10 LPH)
1250-1500	3.0 GPH, (11-12 LPH)	3.5 GPH, (13-14 LPH)
1500-2000	3.5 GPH, (13-14 LPH)	4.0 GPH, (15-16 LPH)
2000-3000	4.5 GPH, (17 LPH)	5.0 GPH, (18-19 LPH)

4. Referring to Table 2, turn switches 6, 7, 8 and 9 ON or OFF, as necessary to get the instrument to read the amount selected from Table 1. If the instrument reads lower than the value selected, use the (+) percentages to increase its reading. If the instrument reads higher than the value selected, use the (-) percentages to decrease its reading. Begin by adding, or subtracting 0.5% from the reading. Continue in 0.5% increments until the desired reading is obtained.

Table 2	Switches				Change factor
	6	7	8	9	
Initial Position →	Off	Off	Off	Off	-2.0%
	On	Off	Off	Off	-1.5%
	Off	On	Off	Off	-1.0%
	On	On	Off	Off	-0.5%
	Off	Off	On	Off	0%
	On	Off	On	Off	+0.5%
	Off	On	On	Off	+1.0%
	On	On	On	Off	+1.5%

	Switches				Change factor
	6	7	8	9	
	Off	Off	Off	On	+2.0%
	On	Off	Off	On	+2.5%
	Off	On	Off	On	+3.0%
	On	On	Off	On	+3.5%
	Off	Off	On	On	+4.0%
	On	Off	On	On	+4.5%
	Off	On	On	On	+5.0%
	On	On	On	On	+5.5%

Example:

The instrument reads 0 GPH after the engine warms up. Referring to Table 2, add 0.5% to the GPH reading, (Turn switch 6 ON). If the instrument continues to read low, increase the GPH reading another 0.5%, (Turn switches 6 OFF, and 7 ON). Continue to increase the GPH reading in 0.5% increments until the desired GPH reading is achieved.

Fuel flow fluctuations of .1 to .2 GPH are fairly common on Marine Diesels when idling. Some governors tend to hunt as they try to maintain a steady, low engine speed.

This completes the return flow calibration procedure. If you're unable to obtain the correct idle setting, refer to the Troubleshooting guide for guidance in locating the problem. If you have any questions or have a problem you can't solve, call the FloScan Technical Service Department for assistance.

Totalizer Calibration:

1. Fill the fuel tank(s) and reset the totalizer.
2. Operate the boat as you normally would.
3. Do at least two fill ups and determine the difference between the fuel consumed and your totalizer reading.
4. Calculate the percentage difference, using this formula:

$$\frac{\text{Difference in Gallons}}{\text{Totalizer Reading}} \times 100$$

5. Turn ON the combination of switches 1, 2 and/or 3 which equal that difference.

Example:

You determine the totalizer reading is 6.5% lower than what actually was actually used. The combined percentage total of switches 1 (2%) and 2 (4%) is 6%. Turn switches 1 and 2 and "4" ON.

Switch #4 remains OFF if the totalizer reads higher than the actual fuel used, and is turned ON if the totalizer reading is less than the fuel used.

Switch Positions:

<i>Switch position</i>	<i>Amount of compensation</i>
(1)	2%
(2)	4%
(3)	8%
(4)	OFF Totalizer reading higher ON Totalizer reading lower
(5)	OFF Normal meter damping ON Heavy meter damping

TROUBLESHOOTING

Series 5800-58000, 6500/65000, 6600/66000 CruiseMaster GPH/LPH Instrument

BEFORE CALLING FOR ASSISTANCE, COMPLETE THESE TROUBLESHOOTING CHECKS AND RECORD YOUR FINDINGS. TECHNICAL SUPPORT REQUIRES THIS INFORMATION BEFORE A RETURN AUTHORIZATION WILL BE ISSUED. IT TAKES ABOUT 20 MINUTES AND IS VERY IMPORTANT IN ANALYZING SYSTEM PROBLEMS.

Before starting record the Instrument MODEL # _____ and all Switch settings.

ON									
OFF									
Switch Settings	1	2	3	4	5	6	7	8	9

<i>FAULT</i>	<i>PROBABLE CAUSE</i>	<i>SEE SECTION:</i>
Blank LCD Display.	Wiring	Section I
No Back-Lighting.	Wiring/bulb failure	Section III
Low Totalizer Reading, more than 10%.	Calibration	Calibration sheet
	Sensor orientation/failure	Installation Sheet
High Totalizer Readings, more than 10%.	Incorrect/defective sensor	Operations
	Incorrect switch settings	Manual page
	Suction leak	Section VI
Fluctuating GPH readings.	Suction leak	Section VI
	Low RPM operation	Section VIII
No GPH or Totalizer reading.	Wiring/Instrument failure	Section IV and V
	Sensor orientation/failure	Installation sheet
No Forward or Return Sensor readings.	Wiring	Section IV and V
	Sensor failure	Section II
High Forward or Return Sensor readings.	Suction leak	Section VI
	Wrong switch settings	Calibration sheet
	Sensor orientation	Section VII

I. INSTRUMENT HEAD DIAGNOSTIC TEST:

1. Referring to the wiring diagram, verify that Instrument & Sensor(s) are wired correctly.
2. Verify that all wiring connections are tight and not corroded. Check continuity with an ohmmeter.
3. With power switched ON, measure voltage between the RED and BLACK wires, (Take readings on the **Instrument** side of the butt splice connections). _____ VDC

The voltage reading should be between 12 and 14.5 VDC. Proceed to step 4 if it is, if not:

- a. Check for voltage between the RED wire and another ground point.
- b. If voltage is present, trace along the BLACK wire until its' open connection is found.
- c. If no voltage is present, trace the RED wire until its' open connection is found.

4. With switched power ON slide, "Dip" switches 1-9 to the ON, or UP position. This places the Instrument into **diagnostic mode**.

NOTE: If the LCD display is blank, verify that the totalizer reset switch, (Connected between the GREEN wire and +12 volts) is in the ON position. Verify that 12 VDC is present between both switch terminals and the Black wire. Next check the, "Green wire" fuse.

5. In, "Diagnostic Mode" the totalizer will count at 1 gallon or 1 liter per second. If it does not, the instrument is defective.
6. With the BLUE wire floating, (Disconnected) the pointer should read approximately:

10 GPH models	9	40 LPH models	35
20 GPH models	18	80 LPH models	70
32 GPH models	28	160 LPH models	140
50 GPH models	45	500 LPH models	450
100 GPH models	90		

7. With the BLUE wire connected to the Instruments' BLACK wire, the pointer should read approximately:

10 GPH models	0.5	40 LPH models	2
20 GPH models	1	80 LPH models	5
32 GPH models	2	160 LPH models	10
50 GPH models	2	500 LPH models	20
100 GPH models	5		

NOTE: If readings are significantly Higher or Lower, the Instrument may be defective.

8. Turn switches 1, 2, 3, 4, 5, 8 and 9 OFF, leave 6 and 7 ON.
9. Disconnect the WHITE and BROWN wires at the instrument. Connect a coarse thread, (½ - 13) or similar non-plated bolt to the BLACK wire.
10. With the BLUE wire disconnected lightly run the WHITE wire up and down the bolt threads. This generates a pulse and should lift the needle off zero. The totalizer should also eventually start counting. Faster movements give higher readings.
11. With the BLUE wire connected to +12 VDC, lightly run the BROWN wire up and down the bolt threads. This generates a pulse and should lift the needle off zero. The totalizer should also eventually start counting. Faster movements give higher readings.
12. If the Instrument passes steps 10 & 11, returns switches 1-9 to their original position and proceed with Part II. If not contact FloScan Technical Support.

II. TEST FLOW SENSOR(S)

1. With the engine idling, connect the BLUE diagnostic wire to Ground. The instrument needle will display fuel flowing through the Forward Sensor _____ GPH
When testing, the scale and readings on 0-10 GPH & 0-40 LPH Instruments increase by a factor of 3.
2. Connect the BLUE wire to +12 VDC. The instrument will display fuel flowing through the Return Sensor. _____ VDC
3. With your voltmeter set to a DC scale greater than 14 volts, measure between the RED (+12VDC) and BLACK (Instrument ground) wires. With engine idling, measure and record the voltage reading. _____ VDC
4. Move the voltmeters' negative lead to the WHITE (Signal) wire. With engine idling, measure and record the voltage reading. It should be approximately 5-7 VDC, about ½ of the reading in step 3. _____ VDC
5. Stop the engine while observing the voltmeter. Voltage readings should fluctuate between a high of 9 to 12 VDC, and a low of 0 to 4 VDC as the flow sensors' turbine slows to a stop. _____ VDC

NOTE: This may not be seen on a digital voltmeter.

6. Move the voltmeters' negative lead to the BROWN (signal) wire. With engine idling, measure and record the voltage reading. It should be approximately 5-7 VDC, about ½ of the reading in step 3. _____ VDC
 7. Stop the engine and observe the voltmeter. Voltage readings should fluctuate between a high of 9 to 12 VDC, and a low of 0 to 4 VDC as the flow sensors' turbine slows to a stop. _____ VDC
- NOTE: This may not be seen with a digital voltmeter.
8. The flow sensor may be defective if voltage readings in steps 5 & 7 remain constant when the engine is stopping.

With this guide in hand, contact FloScan Technical Support.

III. BACKLIGHTING.

1. Referring to the wiring diagram, check back lighting bulb and Instrument illumination circuit.

IV. CHECK + 12 VDC and GROUND

1. Turn Instrument power ON, and go to the Instruments back side.
2. Measure between the RED (Power) wire and the BLACK (Instrument ground) wire. This reading should be approximately 12 VDC, but not lower than 10 VDC. _____ VDC
3. If 12 VDC is not present, measure between the RED power wire and a known good ground in the Instrument panel. If you measure 12 to 14 VDC between the Red wire and ground, you may have an Instrument ground problem. _____ VDC
4. If 12 to 14 VDC is not present in steps 2 or 3, check wiring, switches, fuse, and the 12 VDC power source.

V. CONTINUITY TESTING

1. Continuity testing requires access to the back of the Instrument and an Ohmmeter. It verifies that wires are not broken, shorted to ground, another wire, or to power. Before starting, secure all power.
2. Disconnect the WHITE and BLACK wire harness conductors from the WHITE and BLACK Port Sensor wires. Connect a jumper from the WHITE wiring harness conductor to a known good ground. At the back of the Instrument, connect an Ohmmeter lead to its' WHITE wire. Connect the other Ohmmeter lead to a known, good ground. The Ohmmeter should read approximately 0.1 to 3 Ω. _____ (Ohm Reading)
3. Disconnect the BROWN and BLACK wire harness conductors from the WHITE and BLACK Starboard Sensor wires. Connect a jumper from the BROWN wiring harness conductor to a known good ground. At the back of the Instrument, connect an Ohmmeter lead to its' BROWN wire. Connect the other Ohmmeter lead to a known good ground. The Ohmmeter should read approximately 0.1 to 3 Ω. _____ (Ohm Reading)

VI. FINDING FUEL SYSTEM SUCTION LEAKS

Two common complaints are Fluctuating GPH readings, and High Totalizer Readings. These are generally caused by small vacuum leaks between the fuel tank and fuel pump inlet. Generally, fluctuations tend to be between 2 and 4 GPH. Vacuum leaks also affect totalizer accuracy, and usually cause it to read about 15 to 100% high. Vacuum leaks can occur in both gasoline and diesel systems. Larger leaks produce greater fluctuations and higher readings. Except in severe cases, they do not affect engine performance.

A stiff anti-siphon valve or sticking carburetor float valve also cause fluctuating GPH readings, but do not affect totalizer accuracy. If the totalizer reading is within, (+/- 6%) you should repair or replace defective valve.

Finding suction leaks can be a time-consuming chore. When approached properly, they can be found and repaired quickly. Two common places for suction leaks to occur are the primary fuel filter/water separator and/or from a loose valve stem packing nut.

Remove the filter housing and coat all o-rings, gaskets and sealing surfaces with a medium to heavy grease, (Not oil) and reassemble. Grease all valve stem packings and gently tighten gland nuts. **Do not** over tighten, valve handles should be able to turn freely. Tighten all hose clamps and compression fittings (**Do not** over tighten). Run the engine for 5 to 10 minutes and observe GPH readings. If you've found the problem, fluctuations should be reduced to less than ½ GPH.

If this does not cure the problem, temporarily insert a clear piece of fuel resistant tubing in the fuel line. On diesel engines, install it downstream of the forward flow sensor. Run the engine and watch for a constant stream of small bubbles in the clear tube, or an occasional larger bubble. Sometimes shining a light through the tube makes bubbles easier to see.

Have someone observe the clear tube while you shake any flexible fuel hose(s). If the bubble stream continually increases or decreases as you do this, you've found the leak area. Repair or replace as needed. If it is a one-time occurrence, you probably dislodged air trapped in the fuel line.

If you haven't found it yet, the last step is to inspect each pipe joint in the system. You should be able to see joint compound all around the joint. If you do not, that joint is suspect and needs to be resealed. After re-sealing you may need to run the engine for a few minutes to purge any remaining air. You should now see bubble free solid fuel running through the clear tube. If you still see bubbles you missed a leak somewhere, recheck your work. Remove the tube and restore the fuel system to its normal condition.

Fuel Filters:

A dirty fuel filter, or one that is too fine (1-25 micron) will draw vapor bubbles out of the fuel. Replace it with a new 30-micron filter.

VII. FLOW SENSOR ORIENTATION

Sensor orientation is critical for proper operation. All Sensors have their inlet and outlet ports clearly marked (**IN / OUT** or **➔ ➔**). This identifies fuel flow direction. The Sensor must be, "Plumbed" correctly for it to operate properly. There is an additional single arrow on the Sensor body. It is crucial that this single arrow point up **↑**.

VIII. LOW RPM OPERATION

At idle, under a no load condition, it is common for GPH readings to fluctuate slightly. These fluctuations are caused by the engine governor regulating fuel flow to maintain a steady engine RPM.

This concludes Instrument and Sensor testing. If problems persist, contact FloScan Technical Support